

AIPR - raccordement par le bas (option)
AIPR - connection from bellow (optional)

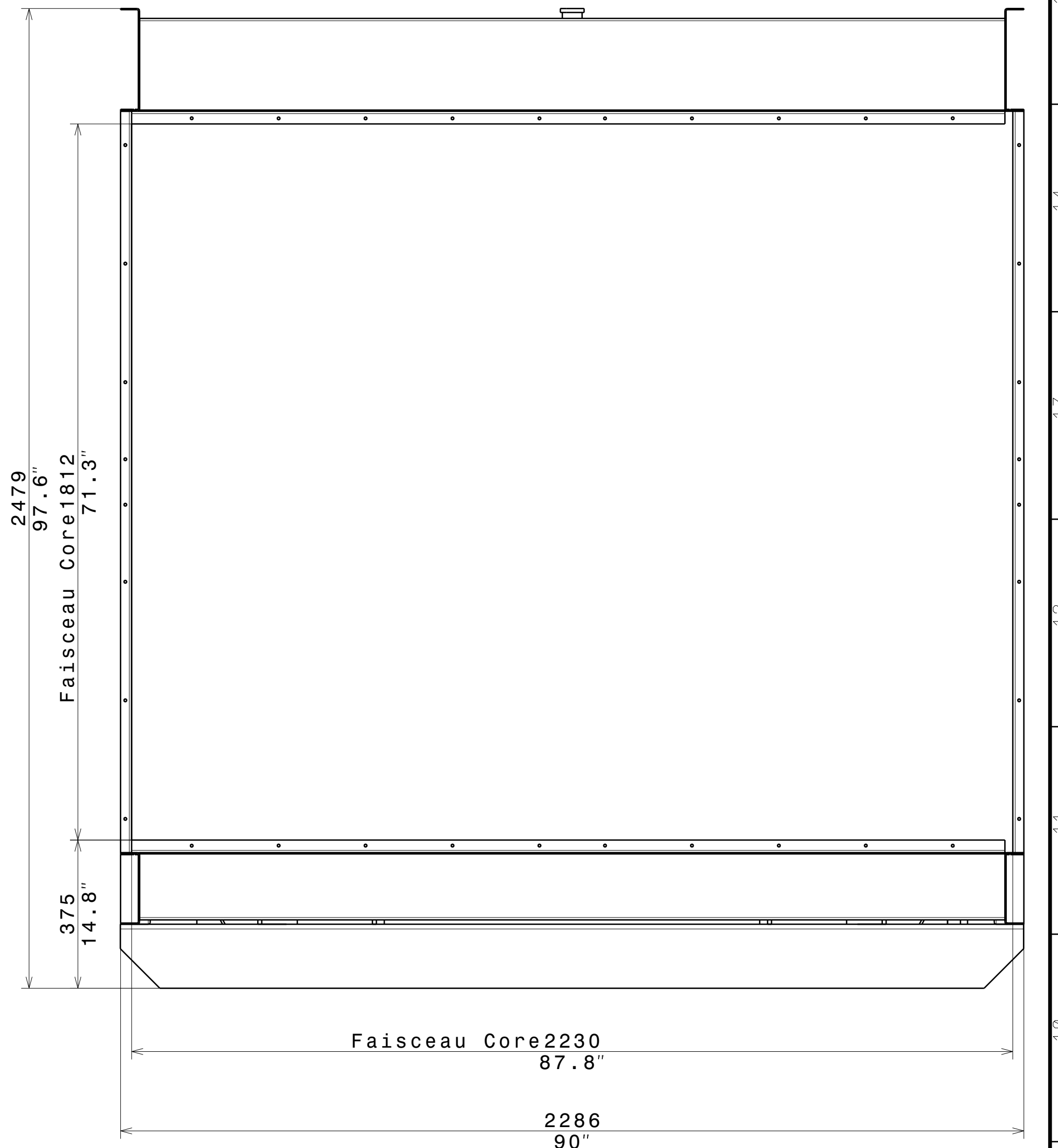

Coupe B-B
Echelle : 1:10

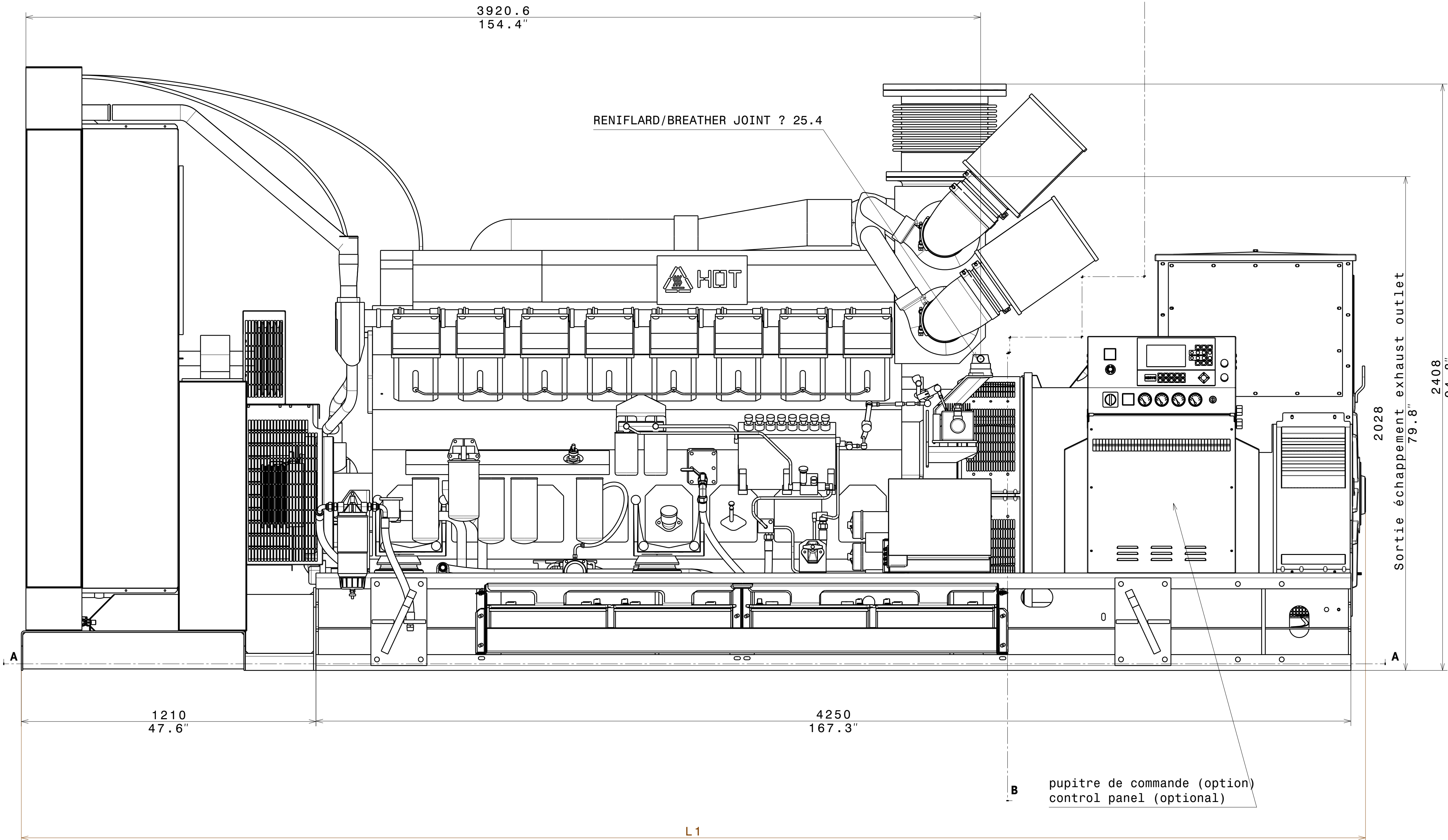
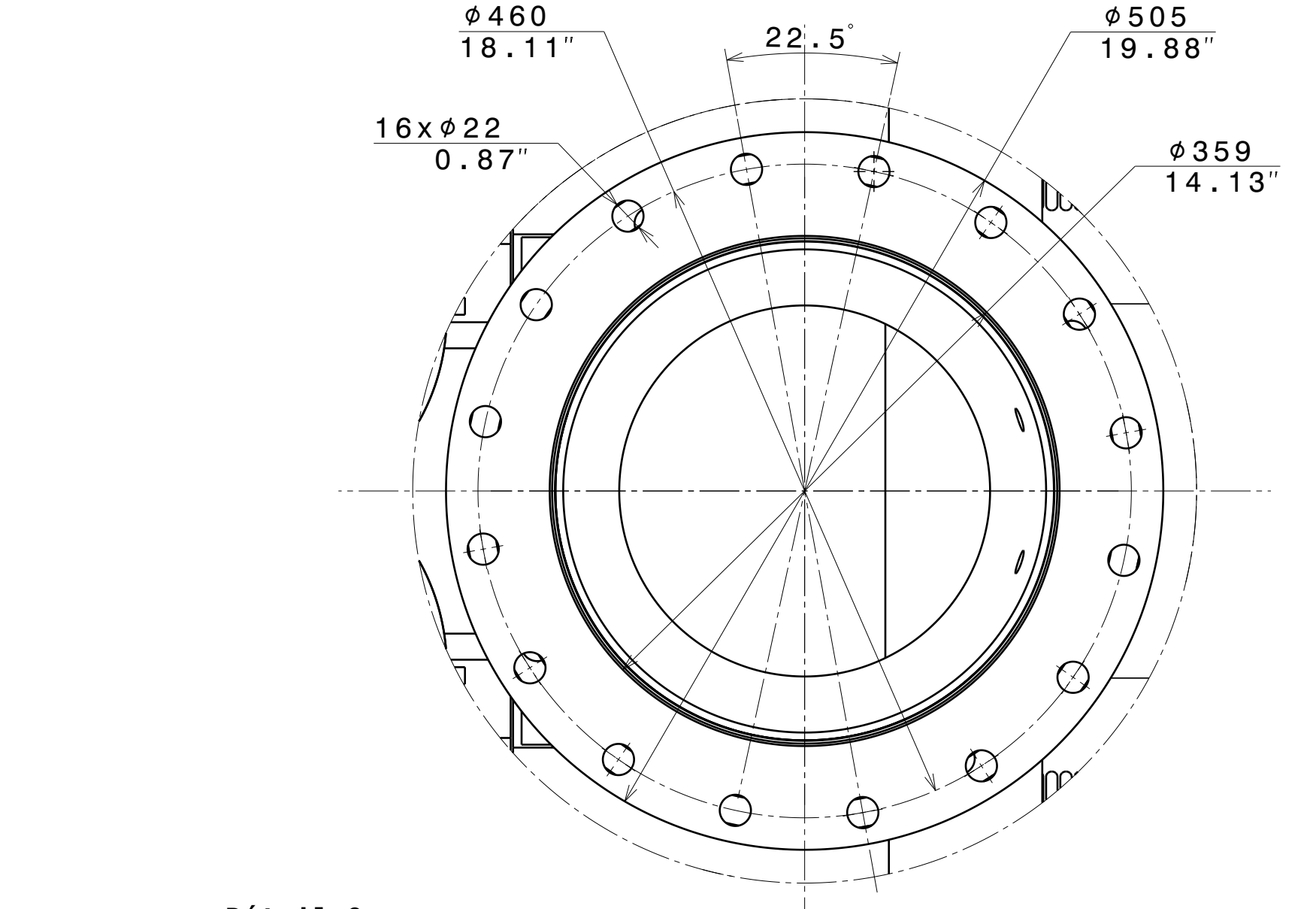
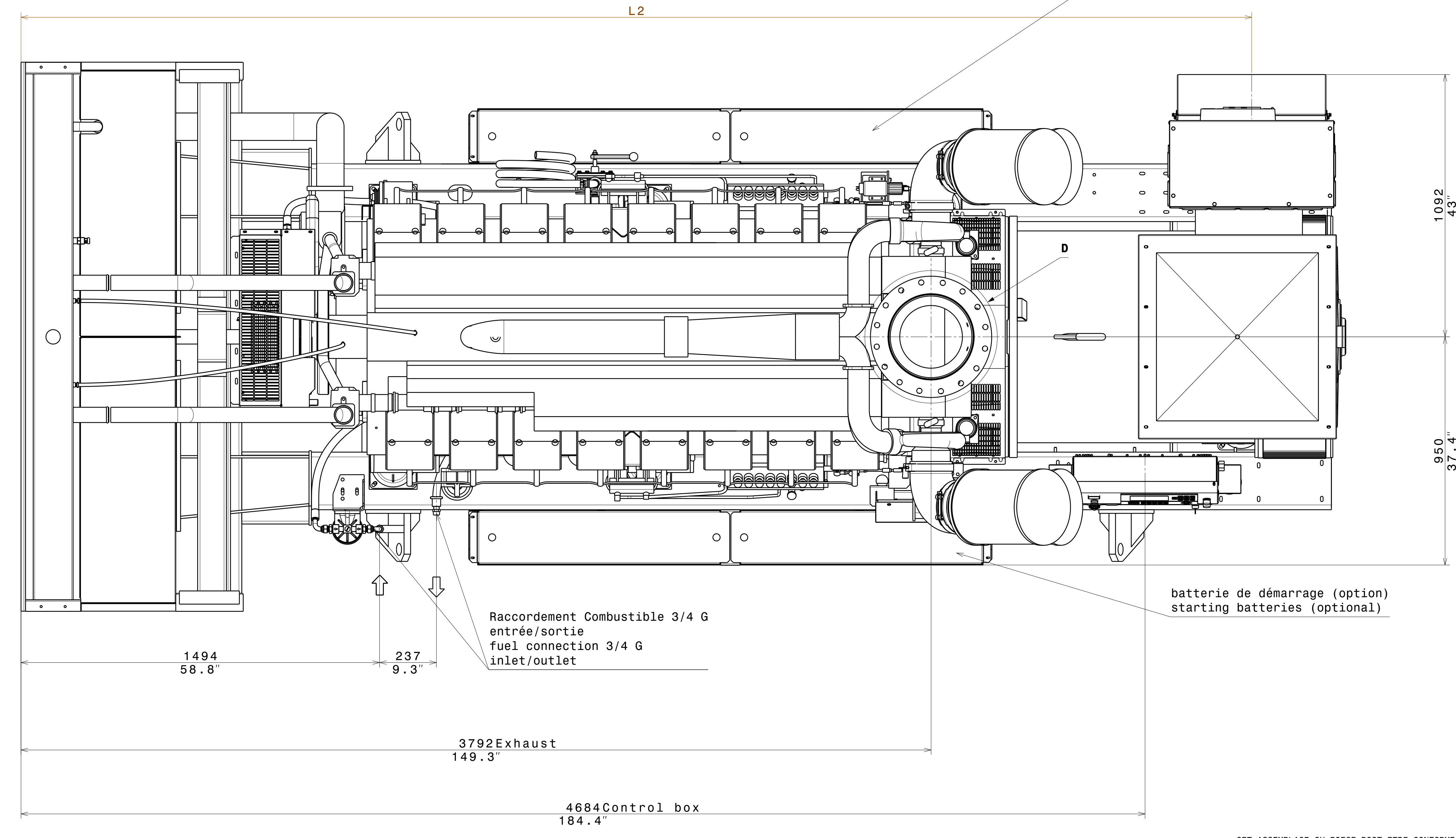
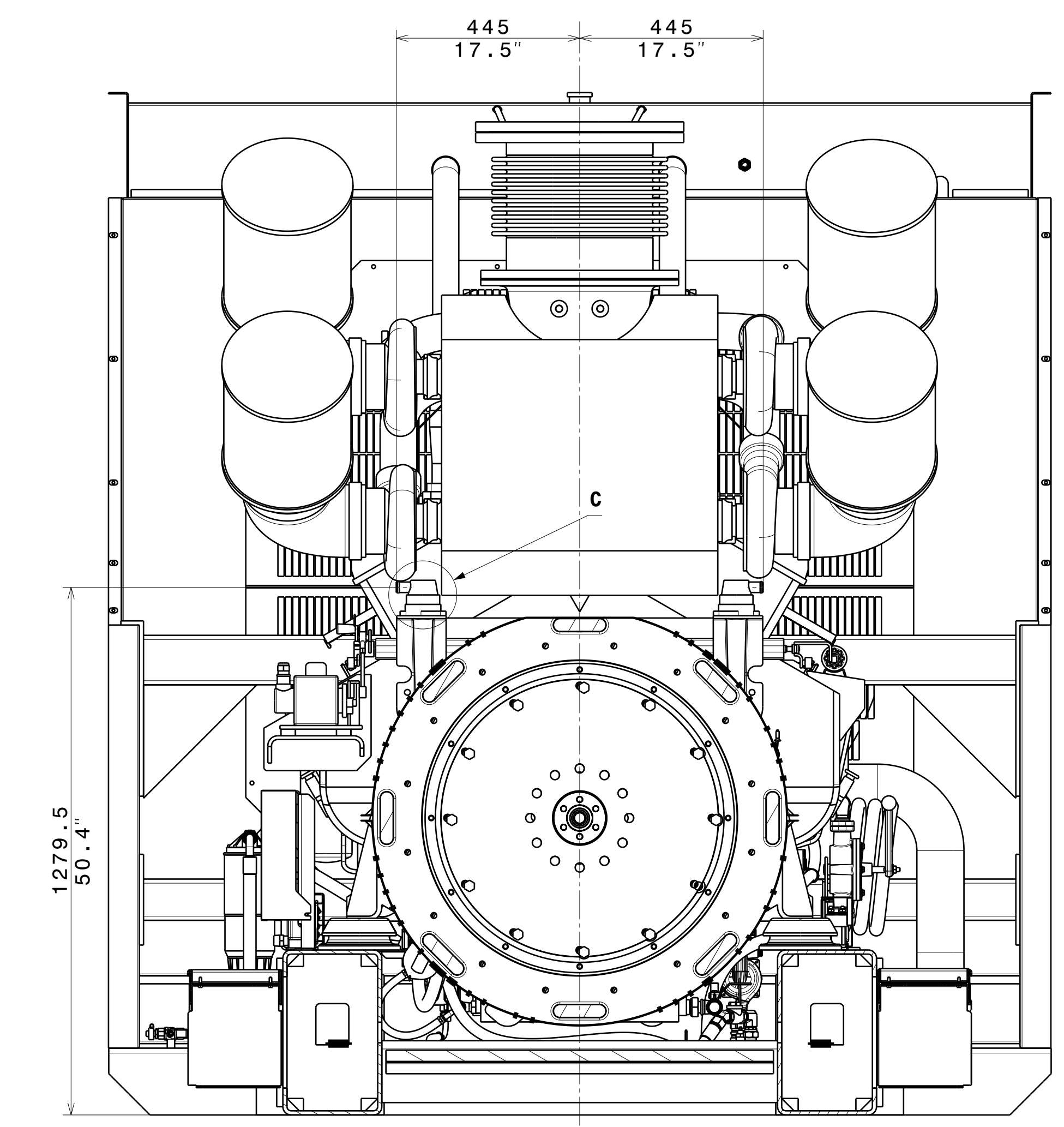

Détail C
Echelle : 1:4

		C.D.G./C.O.G				MASSE/WEIGHT (Kg/lbs)	
L2	L1	SEC/DRY	ODM/WET	MOTEUR/ENGINE	ALTERNATEUR/GENERATOR	A vide/Dry	Odm/Wet
5025	5520	3088	3021	S16R-PTA(2)	KH04402T	12979	13612
5025	5520	3088	3021	S16R-PTA(2)	KH04403T	12979	13612
5025	5520	3123	3055	S16R-PTA(2)	KH04972T	13224	13857
5125	5520	3088	3021	S16R-YIPTA-4	KH04402T	12979	13612
5125	5520	3088	3021	S16R-YIPTA-4	KH04403T	12979	13612
5125	5520	3088	3021	S16R-YIPTA-2	KH04402T	12979	13612
5125	5520	3088	3021	S16R-YIPTA-2	KH04403T	12979	13612

W	Officialisation	PROTO	13/12/21	N° DAO D
L	Designation de la modification (Description of change)	STATUT (Status)	DATE (Date)	VERIFIE (Checked by)
Rev				
Matière (Material)	Tôle (Sheetmetal) : Xmm - Acier (Steel) : S235	Format (Size)	A0	
Revêtement (Coating)	Voir code article (See part number description)	Echelle (Scale)	1/10	
Tolérance (Tolerance)	EN ISO 13920-AE	Folio (Sheet)	1/2	
Designation (Title)	GRUPE ELECTROGENE MI S16R-PTA(2) (GENSET ENGINE MI S16R-PTA(2))	Masse (Weight)	Kg	

CET ASSEMBLAGE OU PIECE DOIT ETRE CONFORME A LA SPECIFICATION PEP-RML-001
THIS ASSEMBLY OR PART MUST COMPLY WITH SPECIFICATION PEP-RML-001

KOHLER
SDMO

30001312901

Rev. : M

Raccordement reniflard
Moteur S16R-PTA(2)
Connection crankcase breather

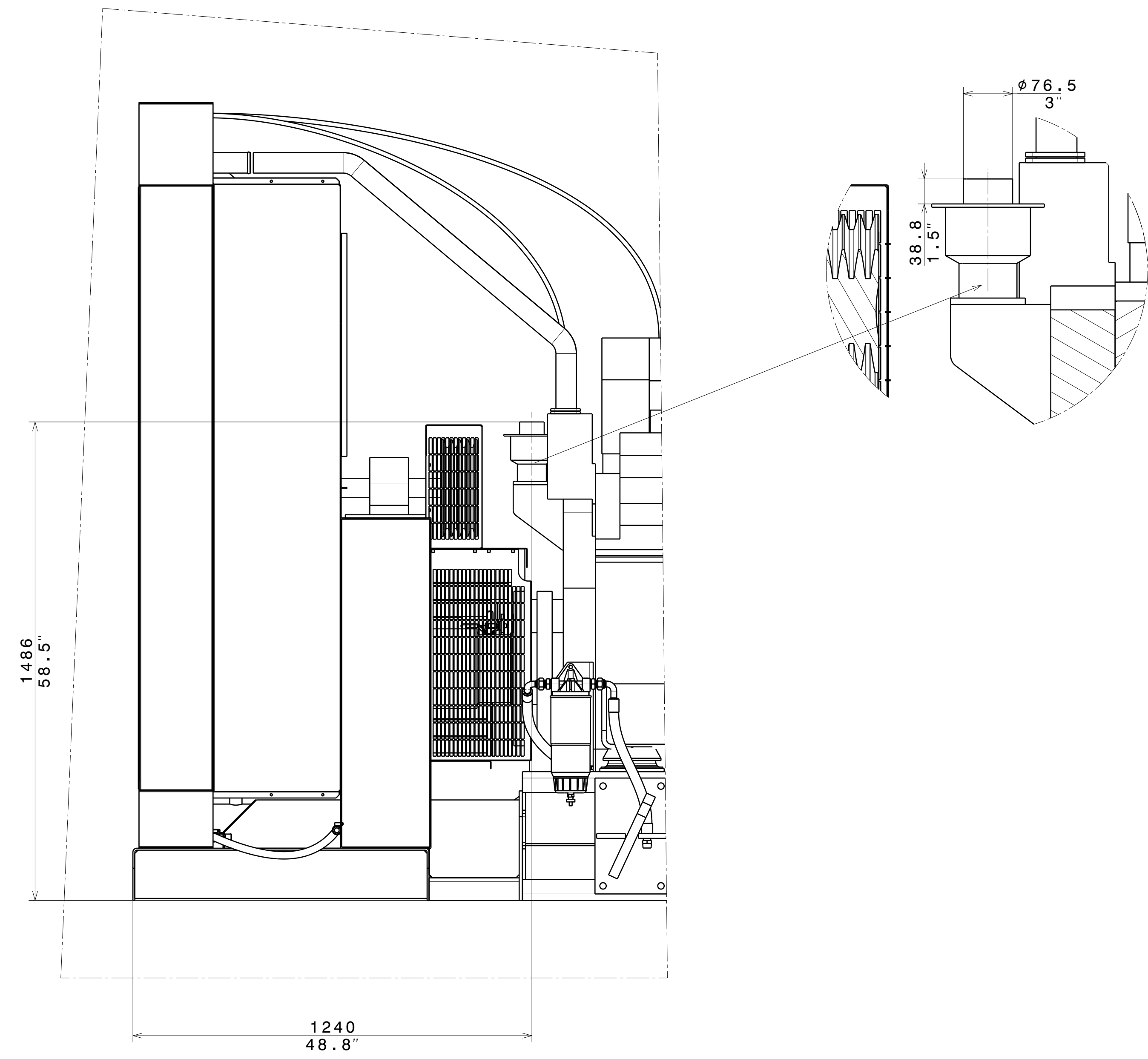

OPTION: FILTRE A AIR POUR AMBIANCE POUSSIEREUSE (4 ELEMENTS)
(OPTIONAL: HEAVY DUTY AIR CLEANER (4 PARTS))

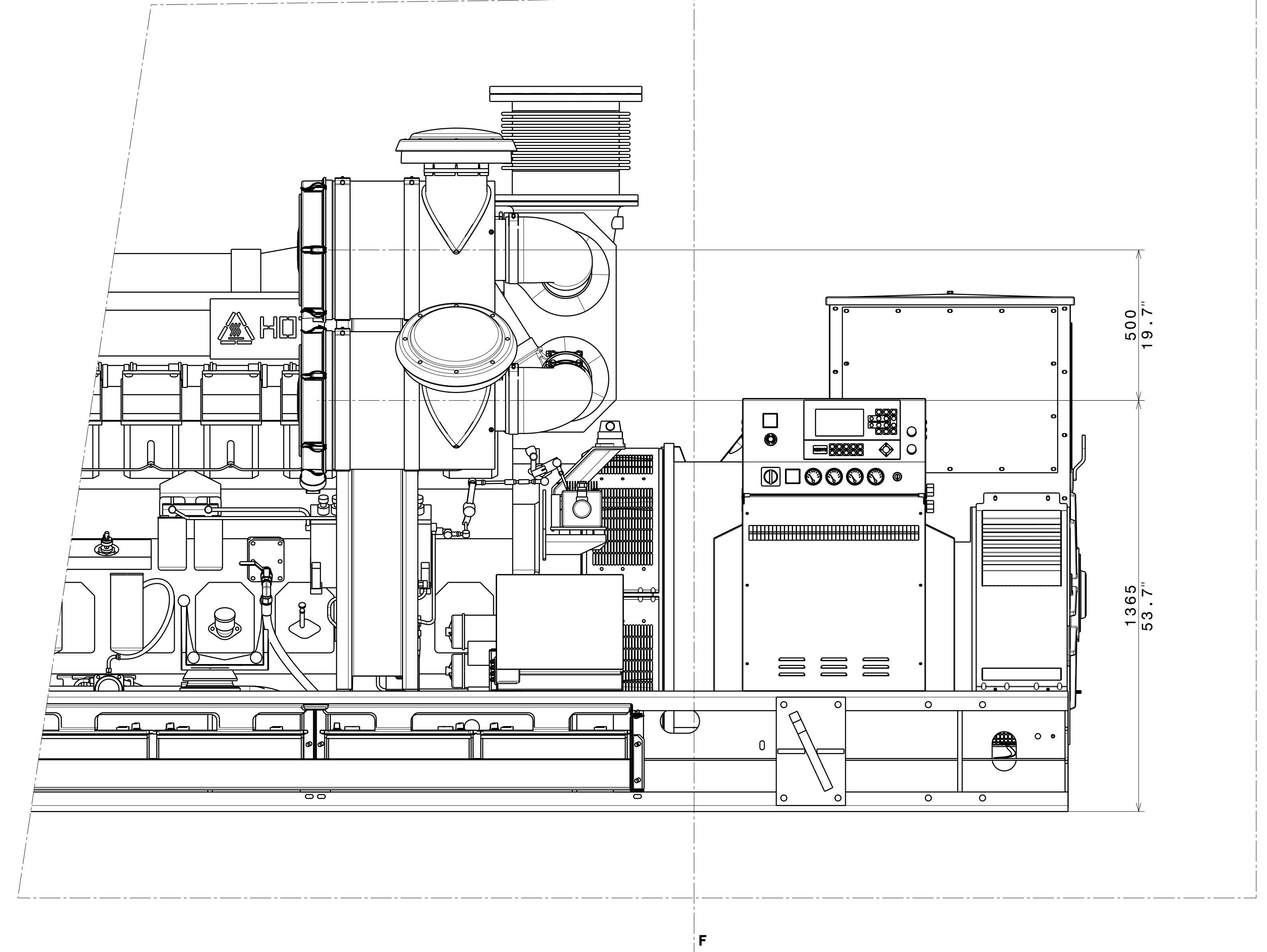
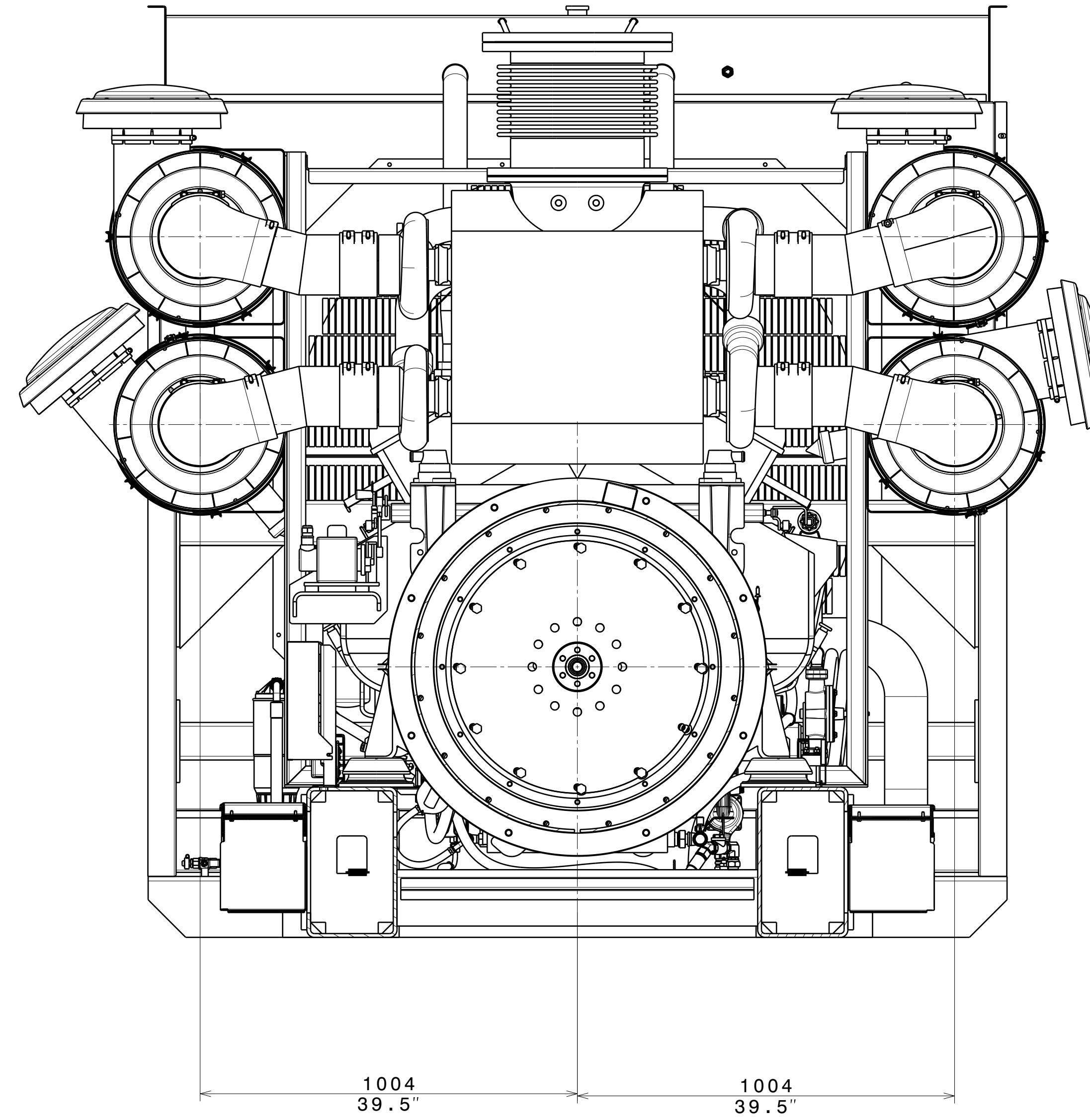

OPTION: Raccordement puissance par le haut
(OPTIONAL: Power connection from the top)
Masse (Weight): +25kg/55Ibs

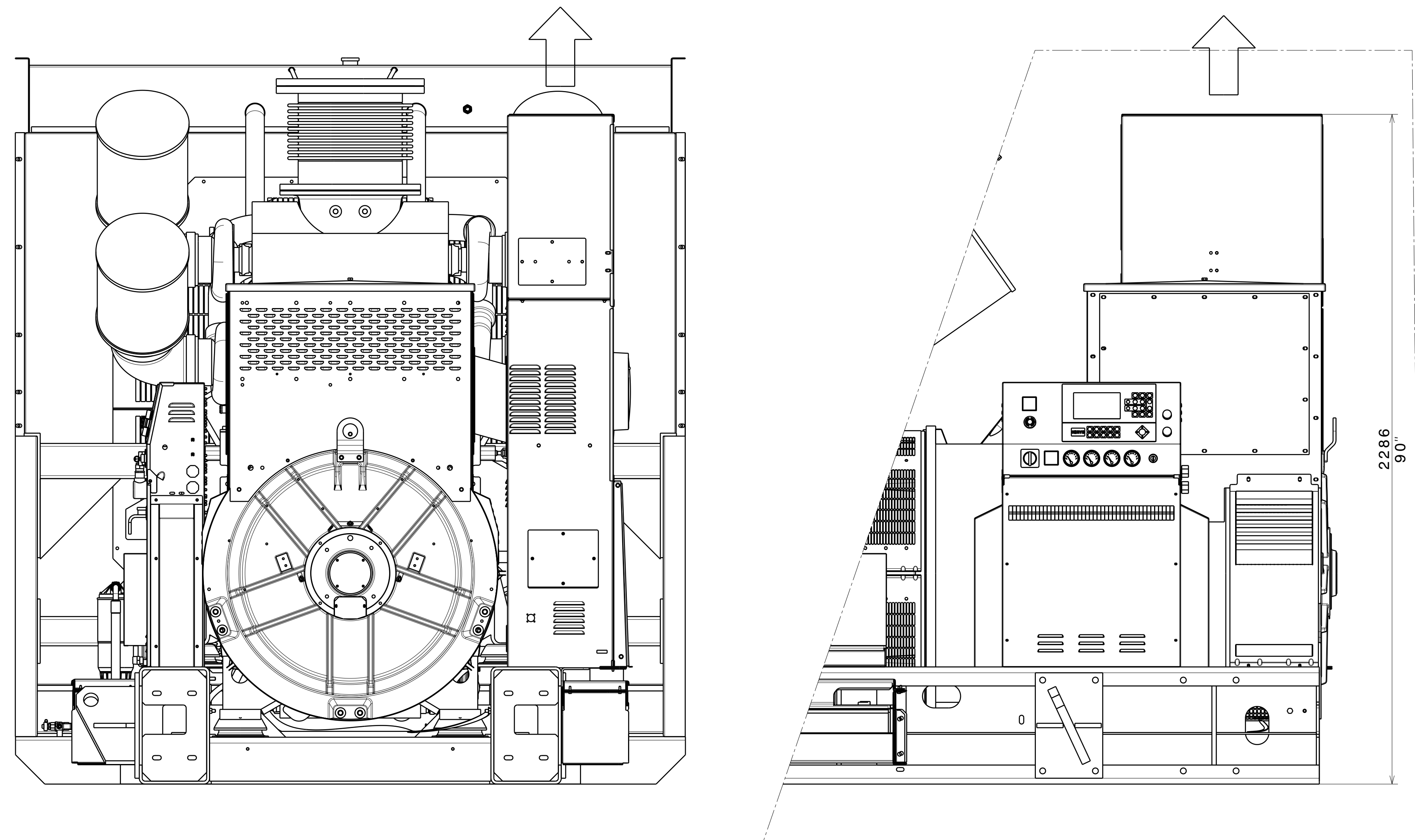

EMPRUNTE AU SOL / GROUND FOOTPRINT
Echelle : 1:10

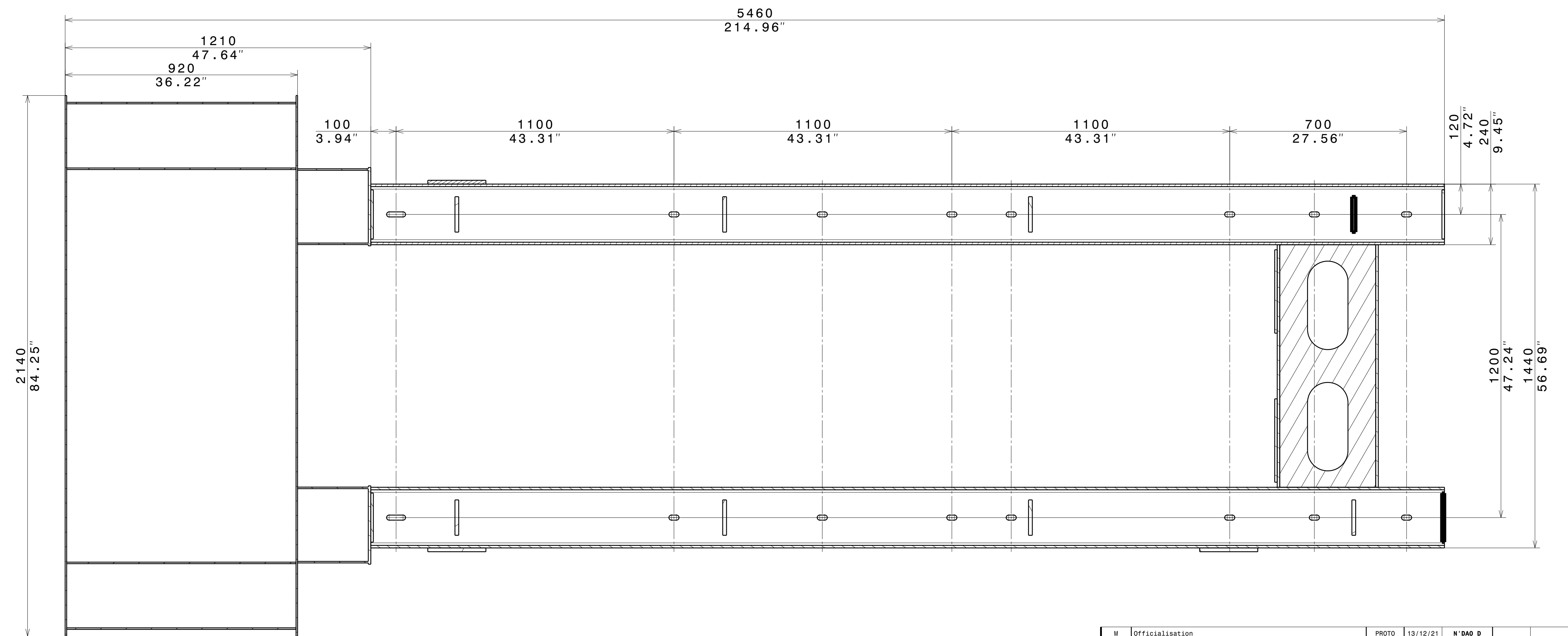

Rev	Officialisation	PROTO	DATE	N° DAO	DATE	VERIF
1	Désignation de la modification (Description of change)	STATUT (Status)	DATE (Date)	N° DAO (Drawn by)	DATE (Date)	VERIF (Checked by)
Matière (Material)	Tôle (Sheetmetal) : Xmm - Acier (Steel) : S235	Format (Size)	A0			
Revêtement (Coating)	Voir code article (See part number description)	Echelle (Scale)	1/10			
Tolérance (Tolerance)	EN ISO 13920-AE	Folio (Sheet)	2/2			
Désignation (Title)	GRUPE ELECTROGENE MI S16R-PTA(2) (GENSET ENGINE MI S16R-PTA(2))	Masse (Weight)	Kg			
M	30001312901	Rev. :	M			

CET ASSEMBLAGE OU PIECE DOIT ETRE CONFORME A LA SPECIFICATION PEP-RML-001
THIS ASSEMBLY OR PART MUST COMPLY WITH SPECIFICATION PEP-RML-001

KOHLER
SDMO