

DETAIL : CONTRE-BRIDE / COUNTER FLANGE

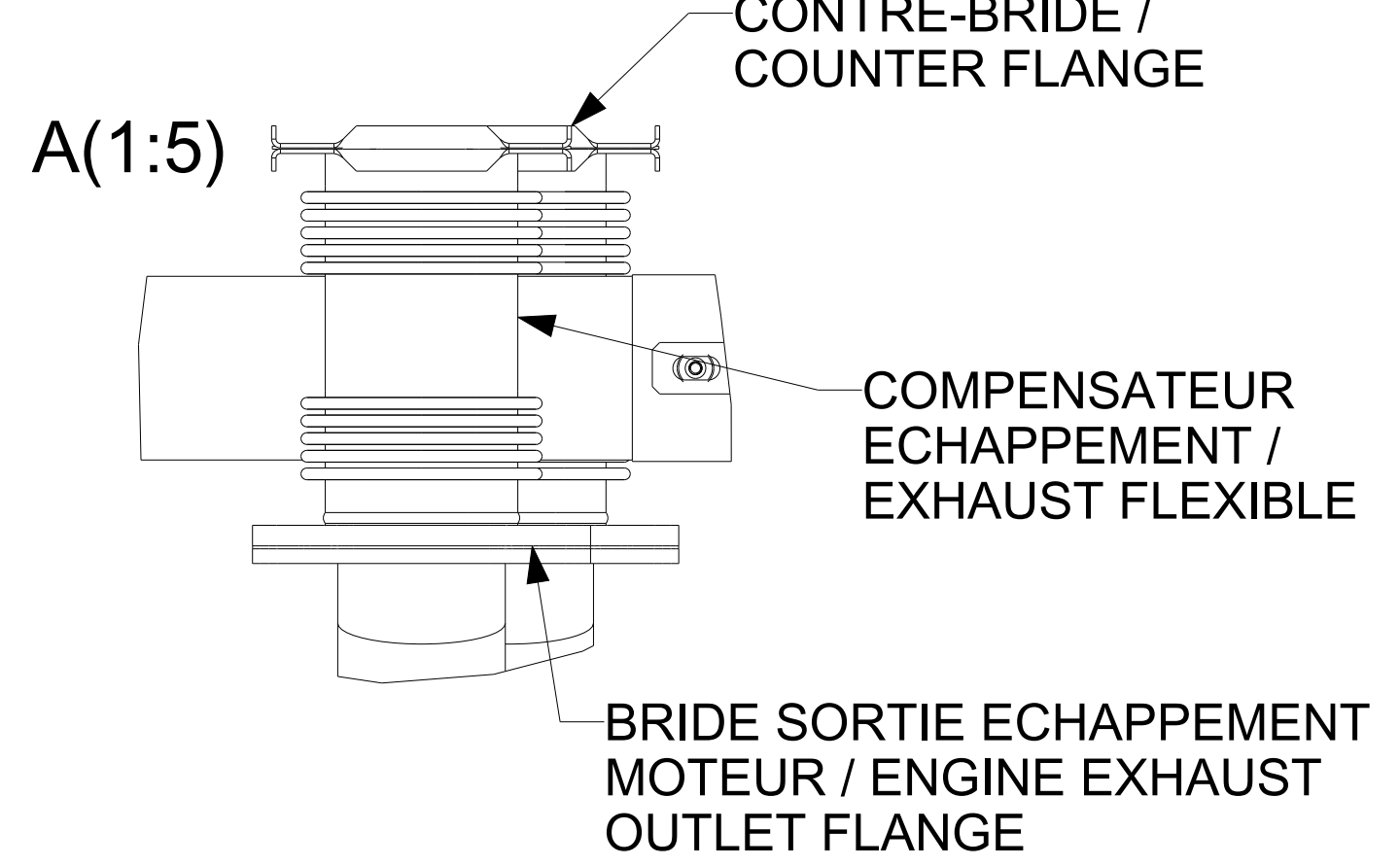

DETAIL : BRIDE SORTIE ECHAPPEMENT MOTEUR / ENGINE EXHAUST OUTLET FLANGE

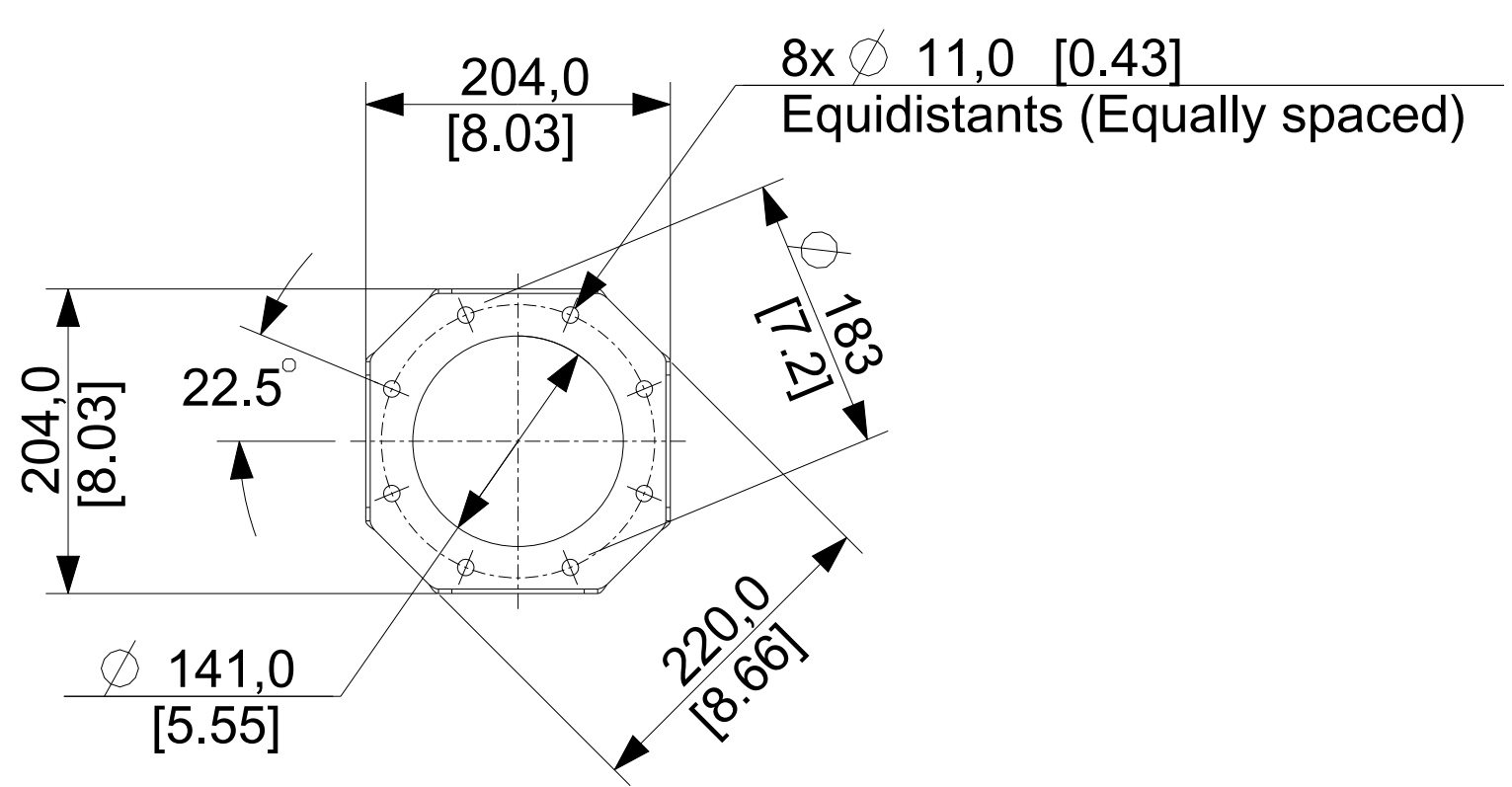
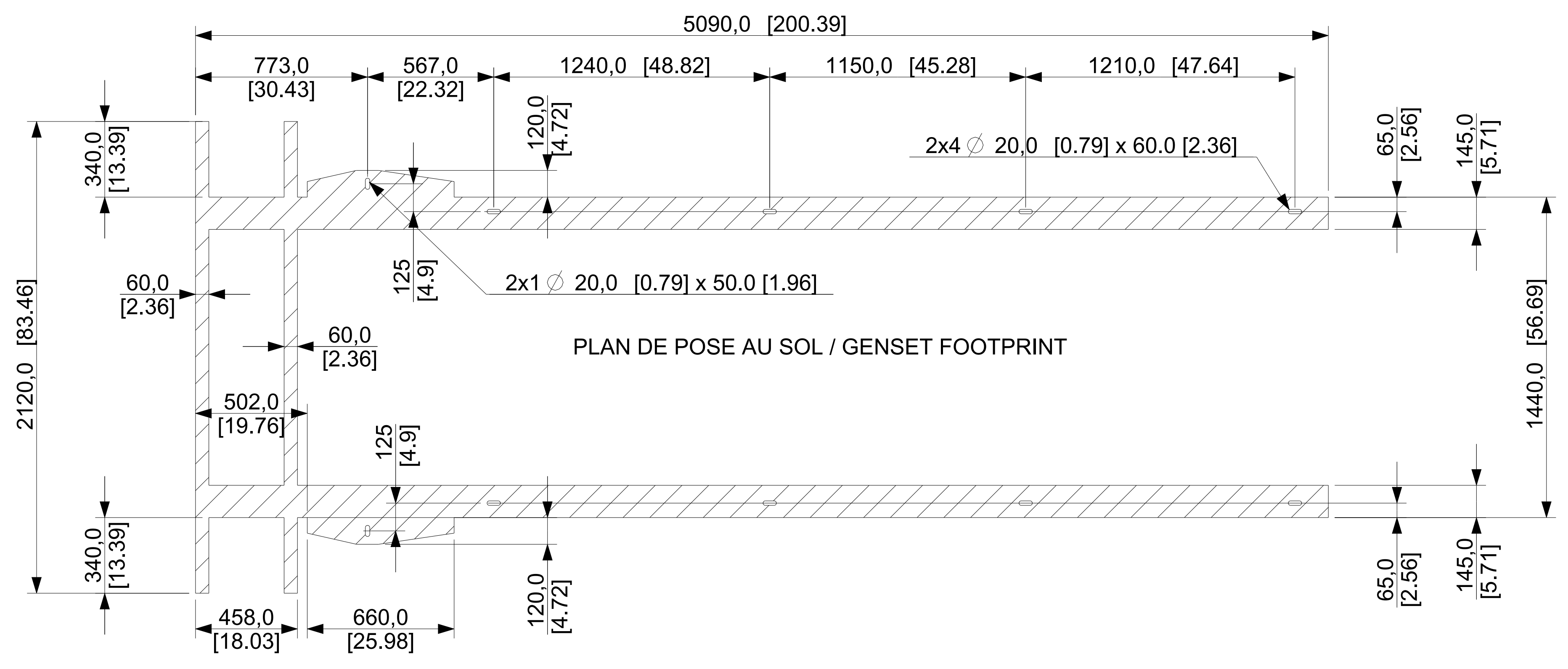
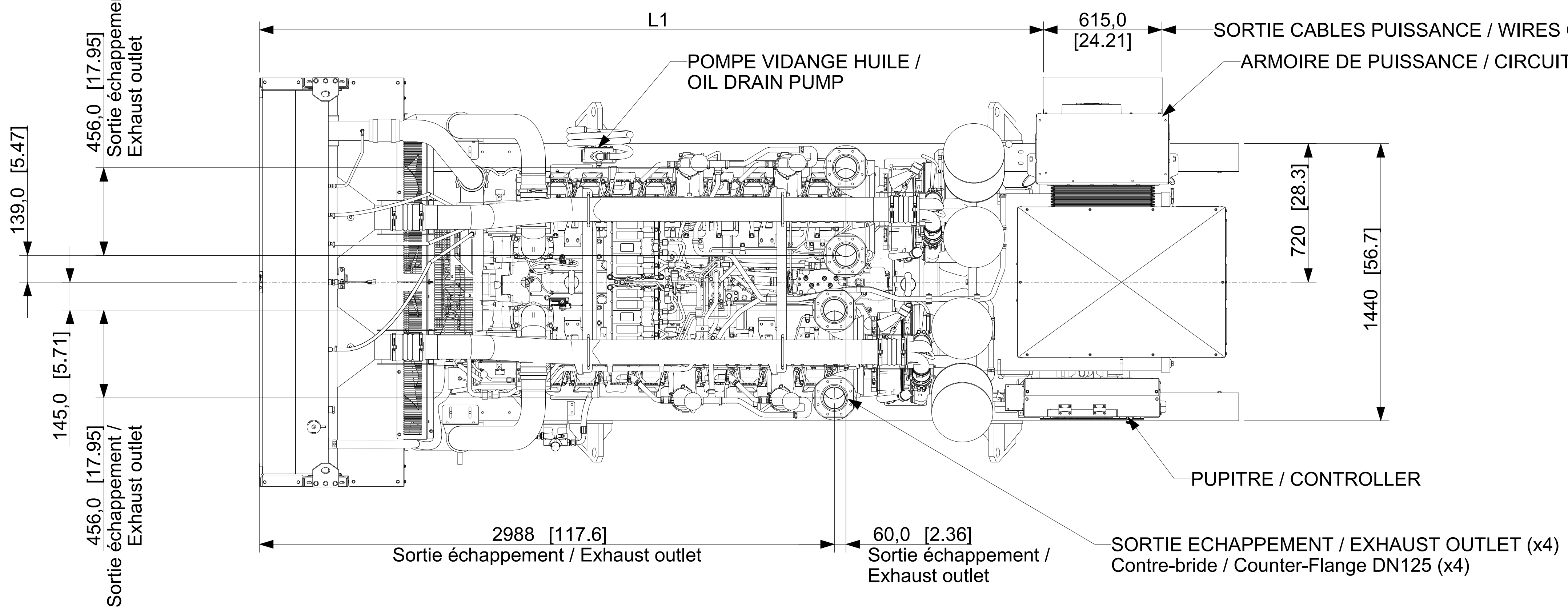
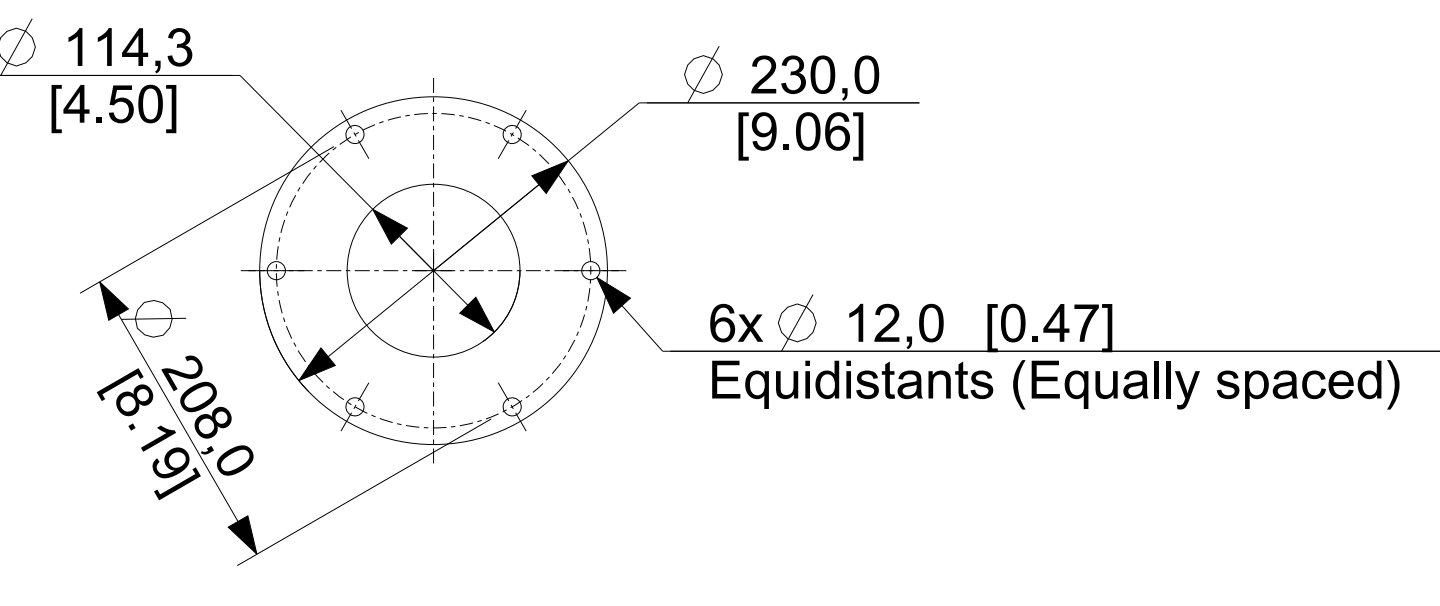

MOTEUR / ENGINE FREQUENCY / FREQUENCY	ALTERNATEUR / ALTERNATOR	L1 (mm / inch)	H1 (mm / inch)	SANS RESERVOIR GASOIL / WITHOUT FUEL TANK						AVEC RESERVOIR GASOIL / WITH FUEL TANK					
				MASSE / WEIGHT (kg / lbs) +/- 5%		COG (mm / inch) A vide / Dry		COG (mm / inch) OdM / Wet		MASSE / WEIGHT (kg / lbs) +/- 5%		COG (mm / inch) A vide / Dry		COG (mm / inch) OdM / Wet	
				A vide / Dry	OdM / Wet	CG Horizontal	CG Vertical	CG Horizontal	CG Vertical	A vide / Dry	OdM / Wet	CG Horizontal	CG Vertical	CG Horizontal	CG Vertical
KD45V20 50Hz	KH04830T	4193 / 165.07	458 / 18.03	9600 / 21164	10000 / 22046	2870 / 112.99	868 / 34.17	2821 / 111.06	867 / 34.13	9800 / 21605	10600 / 23369	2862 / 112.67	854 / 33.62	2798 / 110.15	823 / 32.40
	KH05520T	4193 / 165.07	458 / 18.03	9900 / 21826	10300 / 22708	2922 / 115.03	871 / 34.29	2872 / 113.07	870 / 34.25	10100 / 22267	10900 / 24030	2913 / 114.68	858 / 33.77	2847 / 112.08	827 / 32.55
	KH03850T	4075 / 160.43	555 / 21.85	10000 / 22046	10400 / 22928	2887 / 113.66	871 / 34.29	2839 / 111.77	871 / 34.29	10100 / 22267	11000 / 24251	2879 / 113.34	858 / 33.77	2816 / 110.86	828 / 32.59
	KH04590T	4075 / 160.43	555 / 21.85	10400 / 22928	10800 / 23810	2957 / 116.41	873 / 34.37	2908 / 114.48	872 / 34.33	10500 / 23149	11300 / 24912	2948 / 116.06	860 / 33.85	2882 / 113.46	831 / 32.71
	KH04920T	4075 / 160.43	555 / 21.85	10600 / 23369	11000 / 24251	2977 / 117.20	874 / 34.40	2928 / 115.27	873 / 34.37	10700 / 23589	11500 / 25353	2968 / 116.85	861 / 33.89	2902 / 114.25	832 / 32.75

Ce plan vous est remis à titre indicatif et peut être révisé sans préavis.
This drawing is for informational purposes only and maybe changed without notice.

REV	DATE	DESCRIPTION	BY	CHK
-	10.04.16	NEW DRAWING	AC	AC
A	10.13.17	WEIGHT TABLE UPDATED	AC	AC
B	08.27.23	OPTION ADDED	AC	AC

UNLESS OTHERWISE SPECIFIED:
DIMENSIONS ARE IN MILLIMETERS
TOLERANCES ARE:
FRACTIONS DECIMALS
±0.10 ±0.15 ±0.20 ±0.30 ±0.50 ±1.00 ±1.50 ±2.00 ±3.00 ±5.00

DO NOT SCALE.
THIS ASSEMBLY OR PART MUST
COMPLY WITH THE ORIGINAL
REFERENCE CAD MODEL FOR
UNSPECIFIED DIMENSIONS.

KOHLER

DIMENSION PRINT,
KD45V20
SHEET NO. 30001506701

SCALE: 7:100 (SHEET SIZE: A0) SHEET 1 OF 3

APPROVED: SEE PART SYSTEM DATE: 10.04.16

OPTIONAL :
REPLISSAGE AUTO RESERVOIR FUEL / FUEL TANK AUTO FILLING

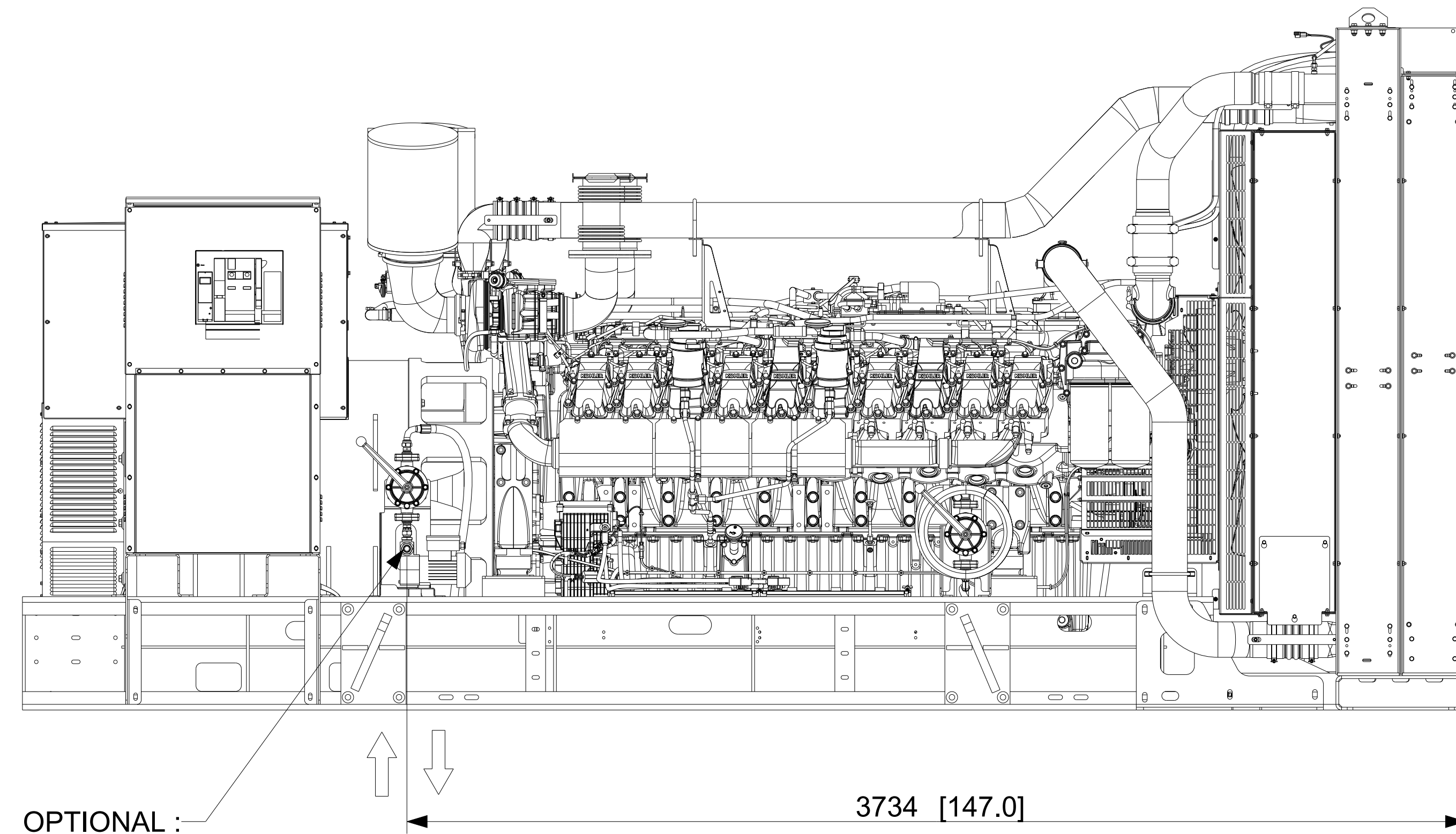

OPTIONAL :
REPLISSAGE AUTO RESERVOIR FUEL /
FUEL TANK AUTO FILLING
- Aspiration / Inlet 3/4" BSPP
- Retour / Outlet 1"1/4 BSPP

OPTIONAL :
RACCORDÉMENT FUEL RESERVOIR SEPARÉ / SEPARATED TANK FUEL CONNECTION

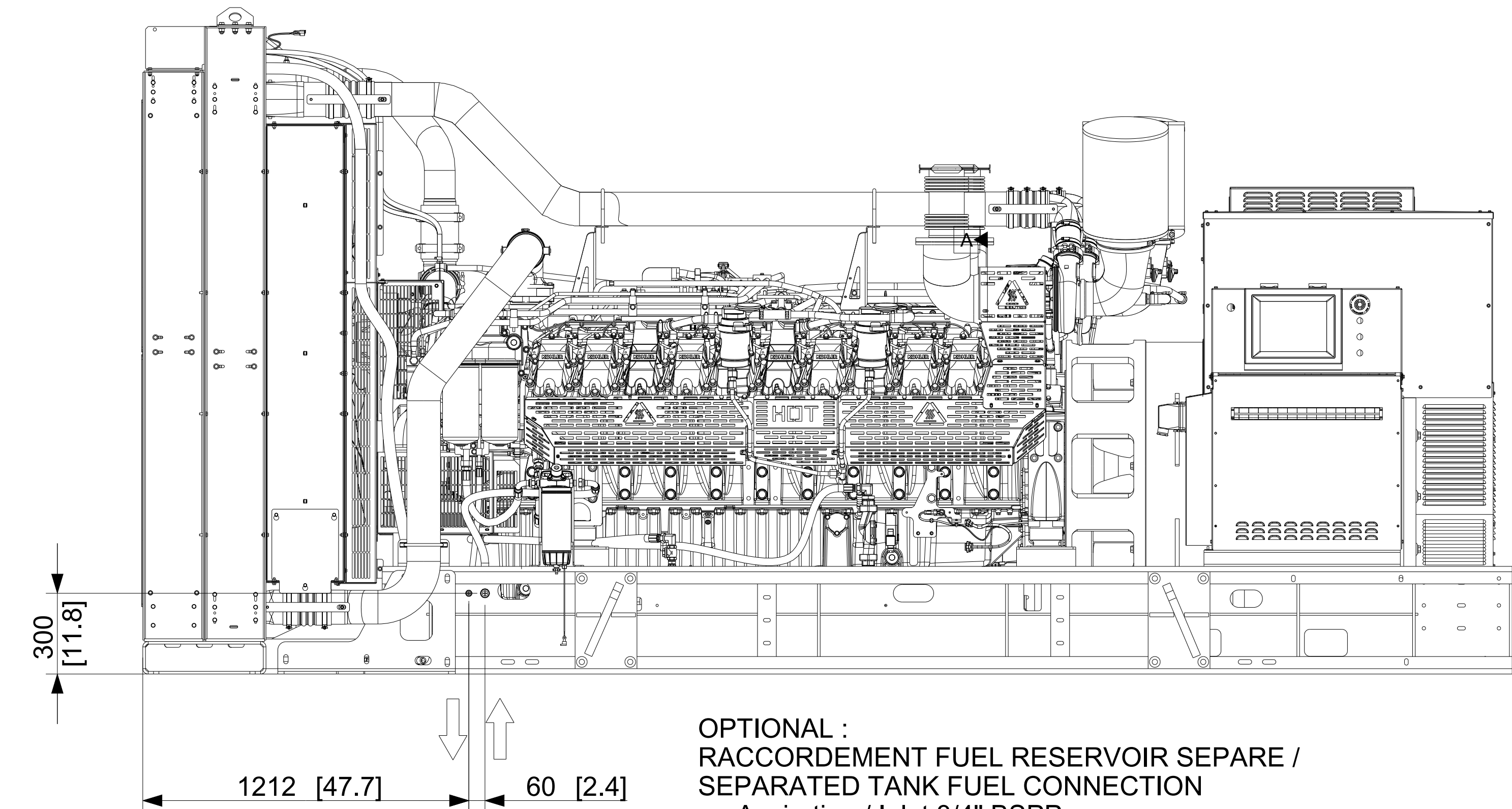

OPTIONAL :
RACCORDÉMENT FUEL RESERVOIR SEPARÉ /
SEPARATED TANK FUEL CONNECTION
- Aspiration / Inlet 3/4" BSPP
- Retour / Outlet 3/8" BSPP

OPTIONAL :
FILTRES A AIR AMBIANCE POUSSIÉREUSE / HEAVY DUTY AIR FILTERS

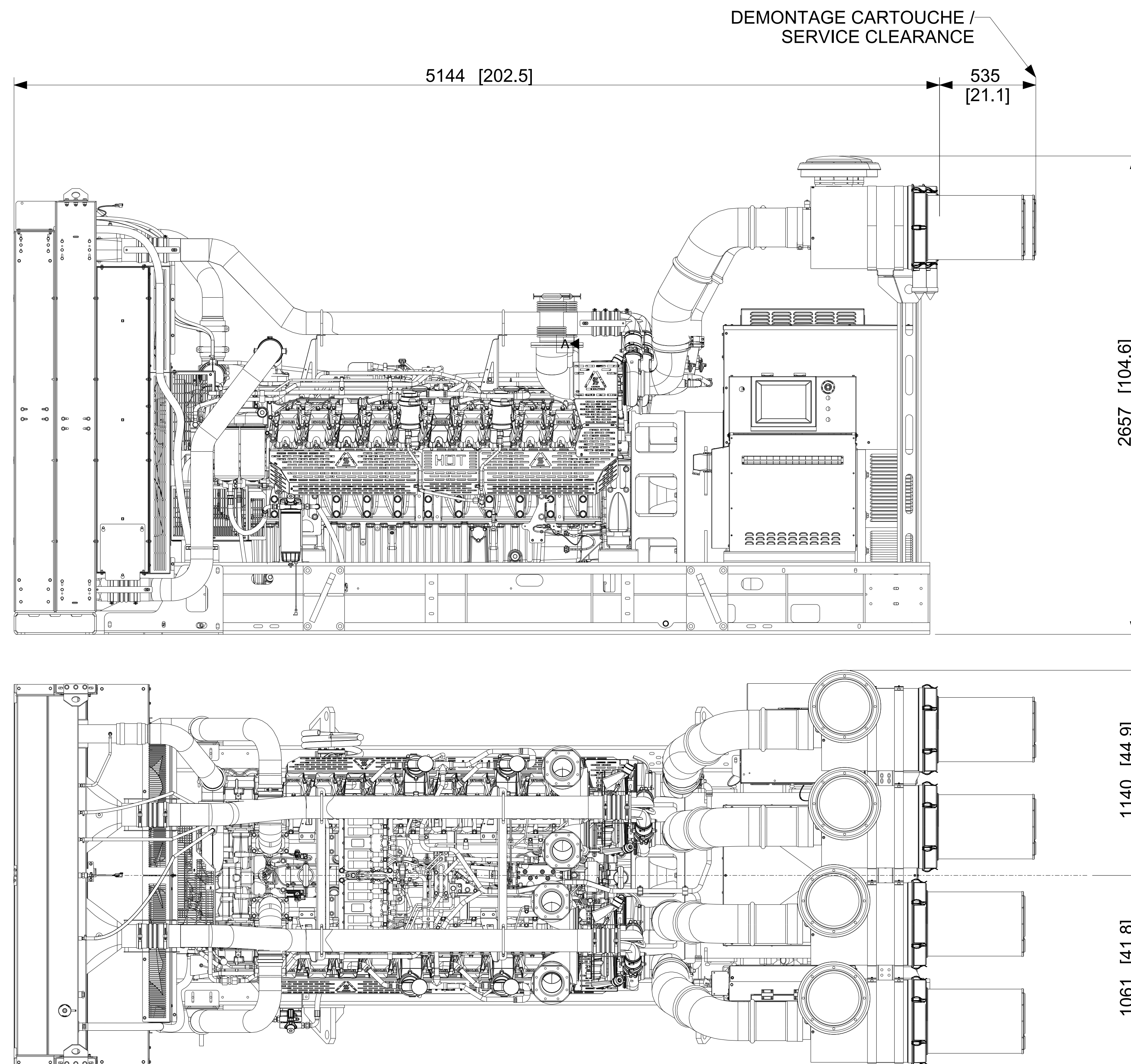

DEMONTAGE CARTOUCHE /
SERVICE CLEARANCE

OPTIONAL :
DOUBLE DEMARRAGE / DOUBLE STARTING SYSTEM

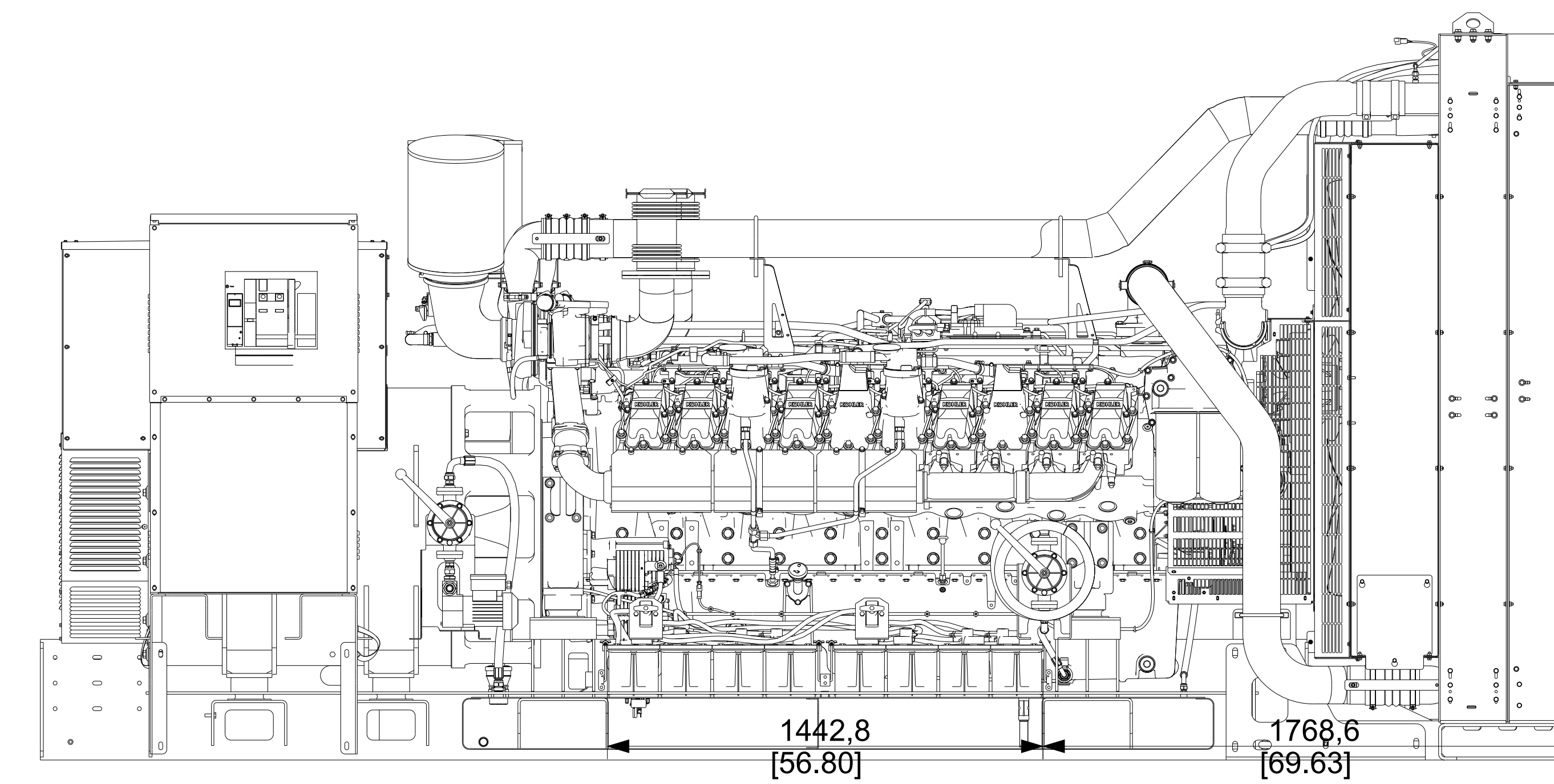

Frame side member hidden to show the batteries

Ce plan vous est remis à titre indicatif et peut être révisé sans préavis.
This drawing is for informational purposes only and maybe changed without notice.

REV	DATE	DESCRIPTION	BY	CHK	APP	DATE
-	10.04.16	NEW DRAWING	AC			
A	10.13.17	WEIGHT TABLE UPDATED	AC			
B	06.27.23	OPTION ADDED	AC			

UNLESS OTHERWISE SPECIFIED: DIMENSIONS ARE IN MILLIMETERS TOLERANCES ARE: FRACTIONAL DECIMALS	DO NOT SCALE. THIS ASSEMBLY OR PART MUST COMPLY WITH ORIGINAL COY. REFERENCE CAD MODEL FOR UNSPECIFIED DIMENSIONS.										
<table border="1"> <tr> <td>PROJ. NO.</td> <td>DATE</td> </tr> <tr> <td>AC</td> <td>10.04.16</td> </tr> </table>	PROJ. NO.	DATE	AC	10.04.16	<table border="1"> <tr> <td>SCALE</td> <td>SHEET NO.</td> <td>TOTAL SHEETS</td> </tr> <tr> <td>7:100</td> <td>A0</td> <td>2 OF 3</td> </tr> </table>	SCALE	SHEET NO.	TOTAL SHEETS	7:100	A0	2 OF 3
PROJ. NO.	DATE										
AC	10.04.16										
SCALE	SHEET NO.	TOTAL SHEETS									
7:100	A0	2 OF 3									
KOHLER DIMENSION PRINT, KD45V20 DESIG. NO. 30001506701											

