

4 trous $\phi 18$ pour fixation au sol
[4 holes $\phi 0.70'$ for fixing on the ground]

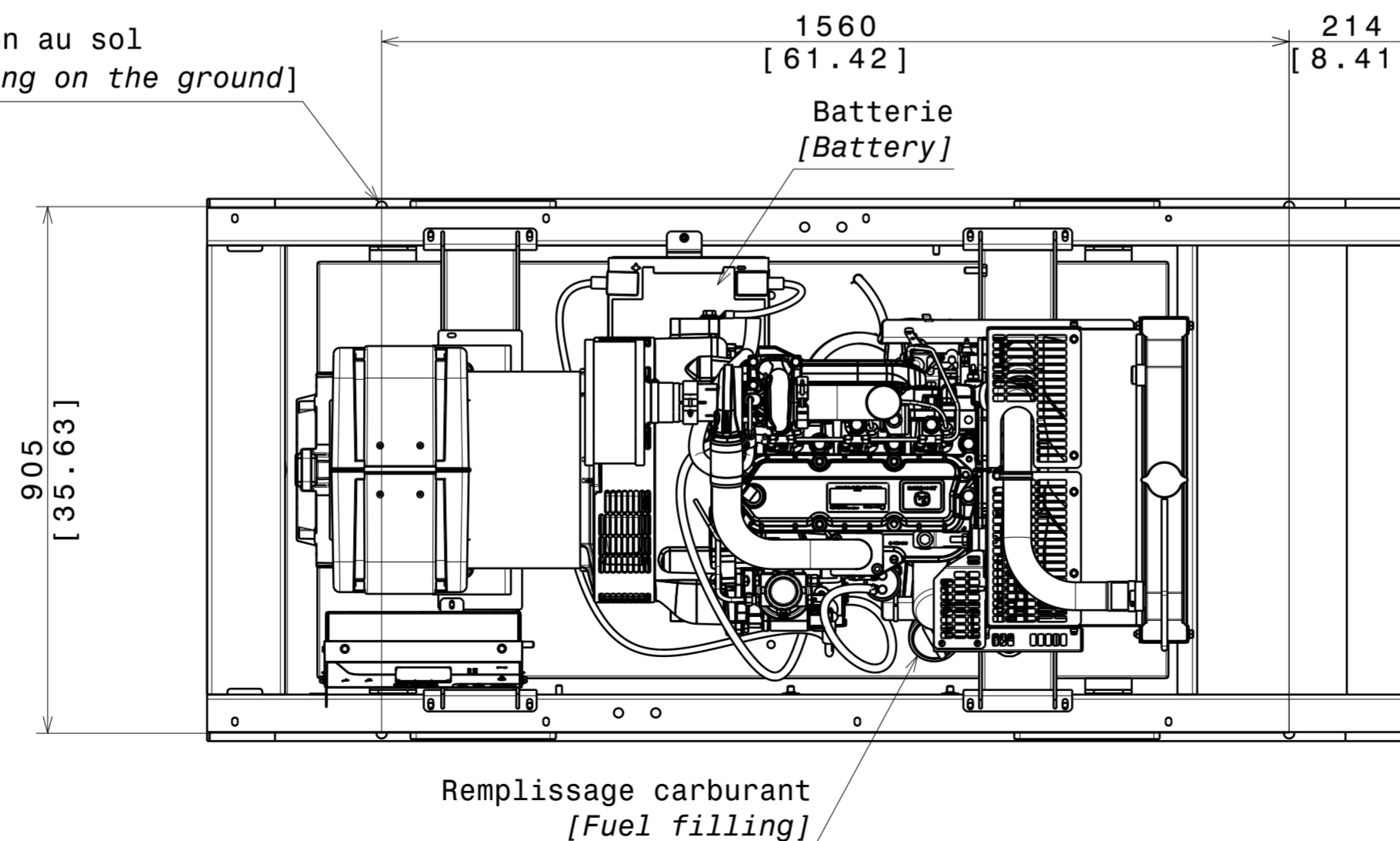

| | | | | | | | | |
|------------------|---------------------------|---------------------|------------|------|-----------|-----------------|------------------------|------|
| 3029T | KH00500T04N | 915 | 2017 | 1145 | 2524 | 1203 | 47.4 | |
| | KH00810TN4N | 902 | 1989 | 1132 | 2496 | 1198 | 47.2 | |
| | KH00601T04N | 879 | 1938 | 1109 | 2445 | 1184 | 48.6 | |
| | KH00602T04N | 888 | 1958 | 1118 | 2464 | 1183 | 46.6 | |
| Moteur Engine | Alternateur Alternator | KH00721T04N | 919 | 2026 | 1139 | 2511 | 1191 | 46.9 |
| | | | kg | lbs | kg | lbs | mm | inch |
| | | | Vide (Dry) | | Odm (Wet) | | Gx | |
| | | TOLERANCE : +/- 5 % | | | | | | |
| | | | | | | Poids Weight | CdG - Odm CoG - Wet | |

| | | | | | | |
|--|--|--------------------|-----------------------------------|--------------------------------------|------|----------------------|
| E | MAJ - AJOUT KH00721T04N | BE | 18/11/20 | PALLIER P | | |
| D | MISE A JOUR POIDS A VIDE (UPDATE DRY WEIGHS) | BE | 10/10/19 | OLIVRE G | | |
| C | COMPLETE TABLEAU CdG | BE | 18/04/18 | OLIVRE G | | |
| B | TABLEAU DES POIDS | BE | 12/04/18 | OLIVRE G | | |
| A | Création du document (First issue) | BE | 17/01/18 | OLIVRE G | | |
| Rev | Désignation de la modification (Description of change) | Statut (Status) | Date Dessiné par (Drawn by) | Visa Vérificateur (Checked by) | Date | Visa |
| Matière (Material) | - | | | Format (Size) | | A2 |
| Revêtement (Coating) | - | | | Echelle (Scale) | | 1/10 |
| Tolérance (Tolerance) | - | | | Folio (Sheet) | | 1/1 |
| Désignation : (Title) | GROUPE - MOTEUR 3029T - RESERVOIR D.W. (GENERATOR - 3029T ENGINE - D.W. TANK) | | | | | Masse (Weight) Kg |
| | | 3-00-01-5165-02 | | Rev.: E | | |
| <small>270 rue de Kerervern CS40047 29801 BREST-GUIPAVAS Cedex 9 FRANCE CE PLAN EST LA PROPRIETE DE SDMO. IL NE PEUT ETRE REPRODUIT, UTILISE OU COMMUNIQUE SANS SON AUTORISATION THIS DRAWING IS UNDER PROPERTY OF THE COMPANY; IT CANNOT BE PRINTED, USED OR COMMUNICATED WITHOUT ITS AUTHORIZATION</small> | | | | | | |

Ce plan vous est remis à titre indicatif et peut être révisé sans préavis
This drawing is for informational purposes only and may be changed without notice