

4 trous Ø18 pour fixation au sol
[4 holes Ø0.70' for fixing to the ground]

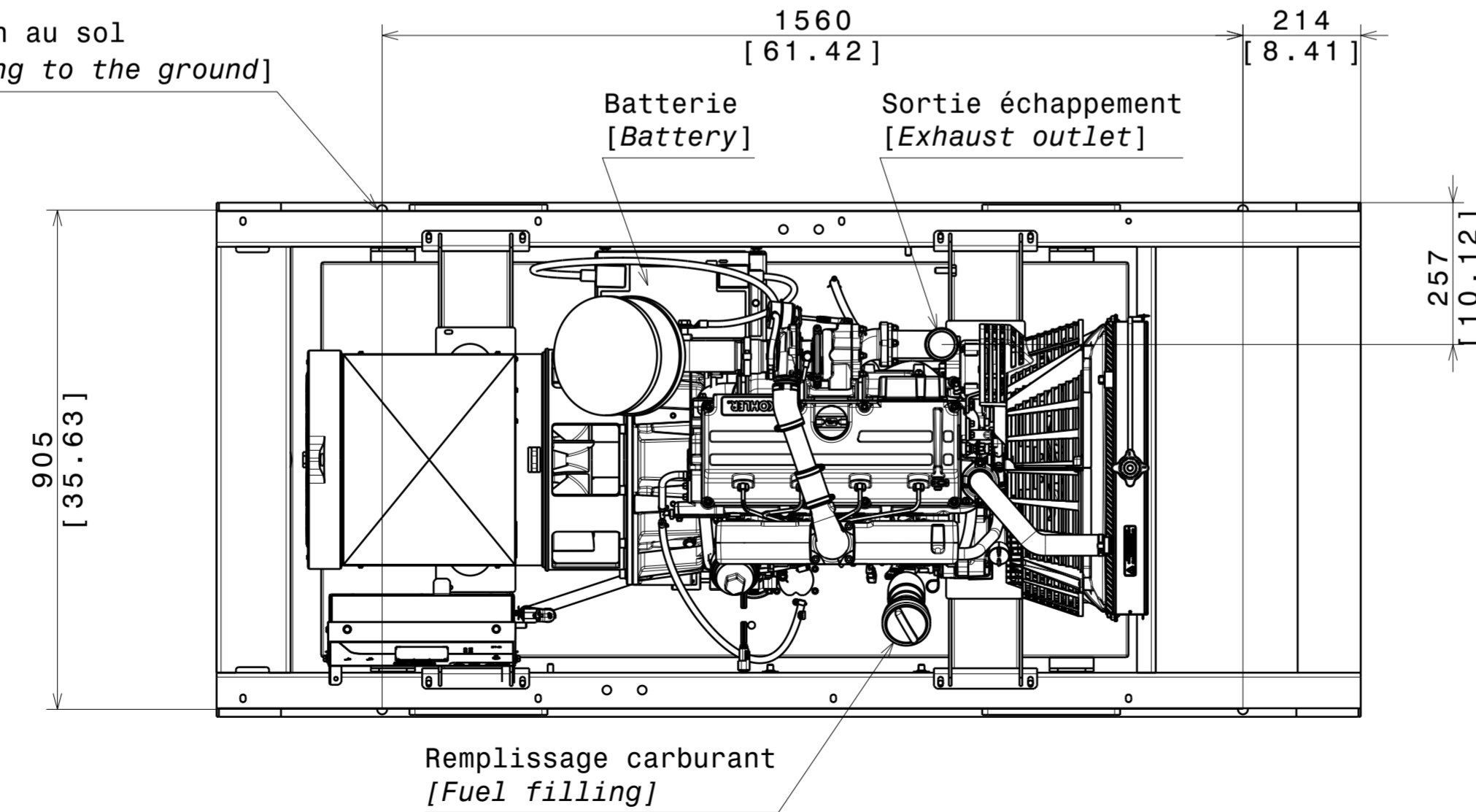

KDI2504TM-40 (EU)	KH00500T04N	836	1843	1062	2341	1216	47.9
	KH00810TN4N	823	1814	1049	2313	1211	47.7
	KH00602T04N	805	1775	1031	2274	1195	47.0
		kg	lbs	kg	lbs	mm	inch
Moteur Engine	Alternateur Alternator	Vide (Dry)		Odm (Wet)		Gx	
		TOLERANCE : +/- 5 %					
		Poids Weight				CdG - Odm CoG - Wet	

D	MISE A JOUR POIDS A VIDE (UPDATE DRY WEIGHS)	BE	10/10/19	OLIVRE G			
C	COMPLETE POSITIONS CDG	BE	19/04/18	OLIVRE G			
B	TABLEAU DES POIDS	BE	12/04/18	OLIVRE G			
A	Création du document (First issue)	BE	17/01/18	OLIVRE G			
Rev	Désignation de la modification (Description of change)	Statut (Status)	Date Dessiné par (Drawn by)	Visa Vérificateur (Checked by)	Date	Visa	
Matière (Material)	-			Format (Size)	A2		
Revêtement (Coating)	-			Echelle (Scale)	1/10		
Tolérance (Tolerance)	-			Folio (Sheet)	1/1		
Désignation (Title)	GROUPE - KDI2504TM-40 - RESERVOIR DOUBLE-WALL (GENERATOR - KDI2504TM-40 - D-W TANK)					Masse (Weight)	Kg
 		3-00-01-5167-02		Rev.: D			
<small>270 rue de Kerervern CS40047 29801 BREST-GUIPAVAS Cedex 9 FRANCE CE PLAN EST LA PROPRIETE DE SDMO. IL NE PEUT ETRE REPRODUIT, UTILISE OU COMMUNIQUE SANS SON AUTORISATION THIS DRAWING IS UNDER PROPERTY OF THE COMPANY; IT CANNOT BE PRINTED, USED OR COMMUNICATED WITHOUT ITS AUTHORIZATION</small>							

Ce plan vous est remis à titre indicatif et peut être révisé sans préavis
This drawing is for informational purposes only and may be changed without notice