

SORTIE ECHAPPEMENT / EXHAUST OUTLET  
(Detail contre-bride / counter-flange detail)

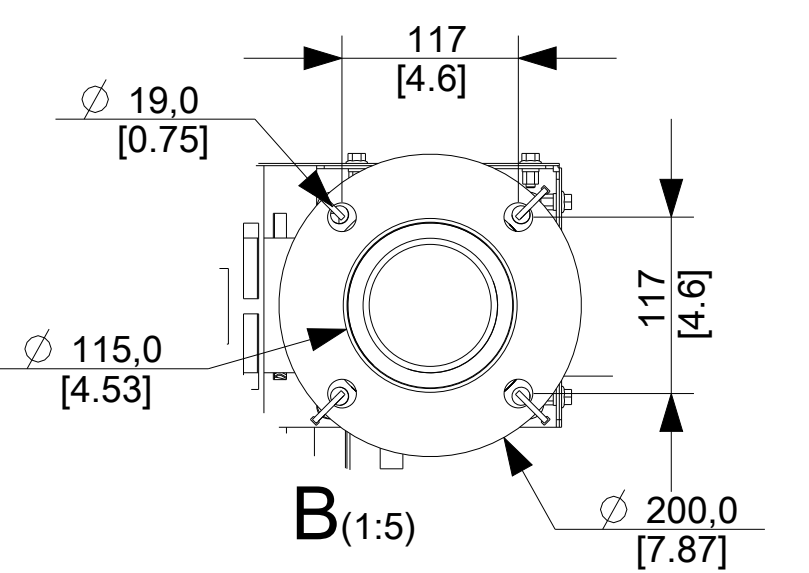

MOTEUR / ENGINE	ALTERNATEUR / ALTERNATOR	CHASSIS AVEC RESERVOIR GASOIL / FRAME WITH FUEL TANK					
		MASSE / WEIGHT (kg / lbs) +/- 5%		COG (mm / inch) A vide / Dry		COG (mm / inch) OdM / Wet	
		A vide / Dry	OdM / Wet	CG Horizontal	CG Vertical	CG Horizontal	CG Vertical
DOOSAN DP180LA	KH03546T	4202 / 9263	4906 / 10815	2178 / 85.74	702 / 27.63	2116 / 83.30	644 / 25.35
DOOSAN DP180LA	KH02954T	3975 / 8763	4680 / 10317	2124 / 83.62	700 / 27.55	2067 / 81.37	640 / 25.19
DOOSAN DP180LA	KH02713T	3893 / 8582	4598 / 10136	2109 / 83.03	700 / 27.55	2054 / 80.86	638 / 25.11

MOTEUR / ENGINE	ALTERNATEUR / ALTERNATOR	CHASSIS SANS RESERVOIR GASOIL / FRAME WITHOUT FUEL TANK					
		MASSE / WEIGHT (kg / lbs) +/- 5%		COG (mm / inch) A vide / Dry		COG (mm / inch) OdM / Wet	
		A vide / Dry	OdM / Wet	CG Horizontal	CG Vertical	CG Horizontal	CG Vertical
DOOSAN DP180LA	KH03546T	3964 / 8739	4118 / 9078	2193 / 86.33	736 / 28.97	2170 / 85.43	736 / 28.97
DOOSAN DP180LA	KH02954T	3738 / 8240	3891 / 8578	2136 / 84.09	736 / 28.97	2114 / 83.22	737 / 29.01
DOOSAN DP180LA	KH02713T	3656 / 8060	3809 / 8397	2121 / 83.50	737 / 29.01	2099 / 82.63	737 / 29.01

(1) Seulement avec châssis réservoir fuel / Only with fuel tank frame

- Voir folios suivants pour informations complémentaires / See following sheets for additional informations.

- Les noms des vues correspondent aux différentes faces du groupe électrogène / The names of the views correspond to the different sides of the generating set.

CET ASSEMBLAGE OU PIECE DOIT ETRE CONFORME A LA SPECIFICATION PEP-RML-001  
THIS ASSEMBLY OR PART MUST COMPLY WITH SPECIFICATION PEP-RML-001

REV	DATE	ON COMPOSITE DWGS. SEE PART NO. FOR REVISION LEVEL	BY	DO NOT SCALE. REFERENCE THE MODEL FOR ALL UNSPECIFIED DIMENSIONS
-	07/06/22	NEW DRAWING	SP	UNLESS OTHERWISE SPECIFIED - 1) DIMENSIONS ARE IN MILLIMETERS 2) TOLERANCES ARE: NF 501300-6-A-E
A	14/03/24	UPDATE	SP	

**KOHLER** 270 rue de Kerenheim - 29490 Guipavas  
CS 40047 - 29801 Brest Cedex 9 - France

THIS DRAWING IS UNDER PROPERTY OF THE COMPANY.  
IT CANNOT PRINTED, USED OR COMMUNICATED WITHOUT ITS AUTHORIZATION.

TITLE: **30001546301**

APPROVALS: P. SIMON DATE: 14-Mar-24 CAD NO: 30001546301 SCALE: 1:10 SHEET: 1 of 3  
APPROVED: DWG NO: 30001546301 REV: SIZE: A A0

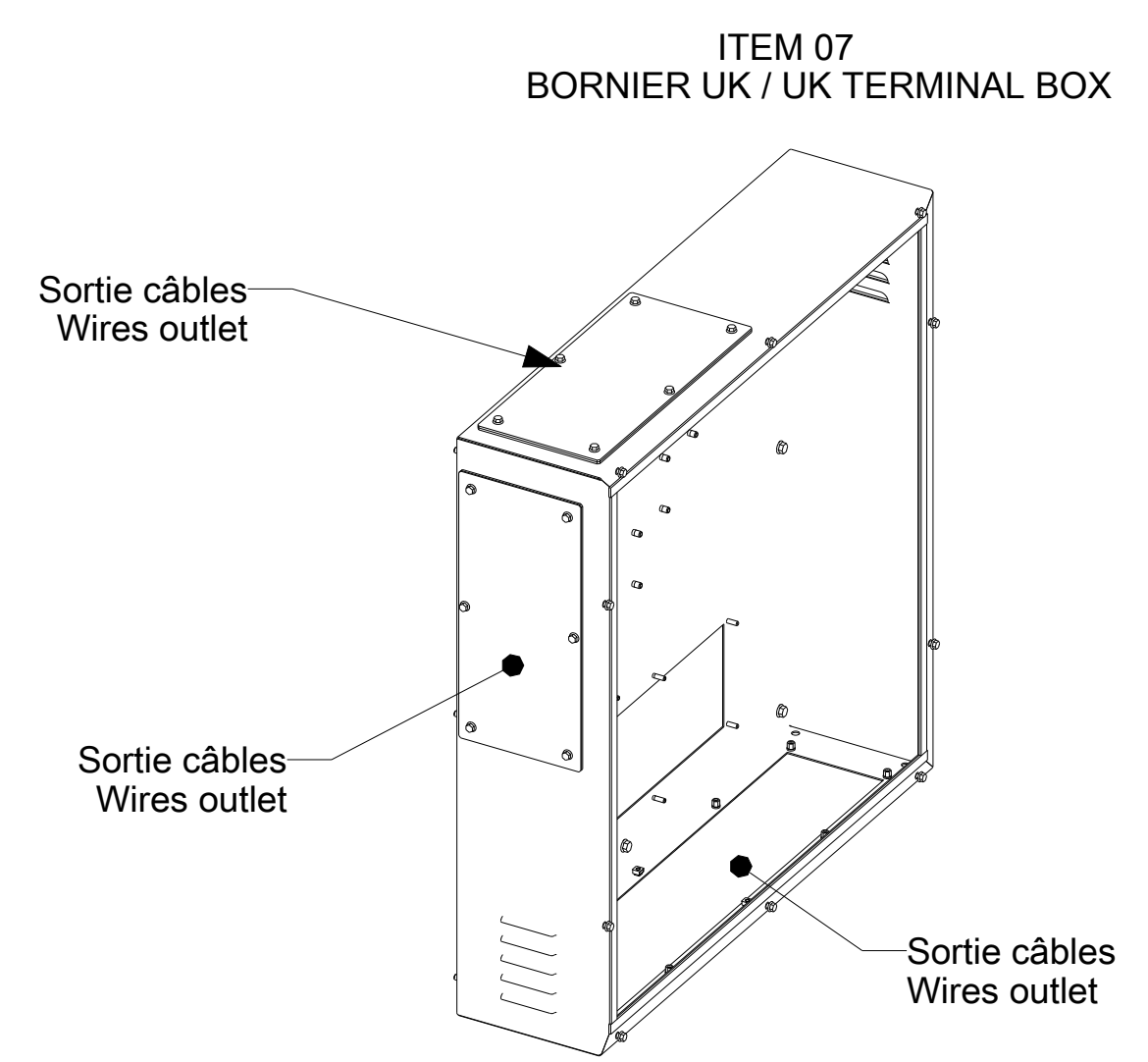
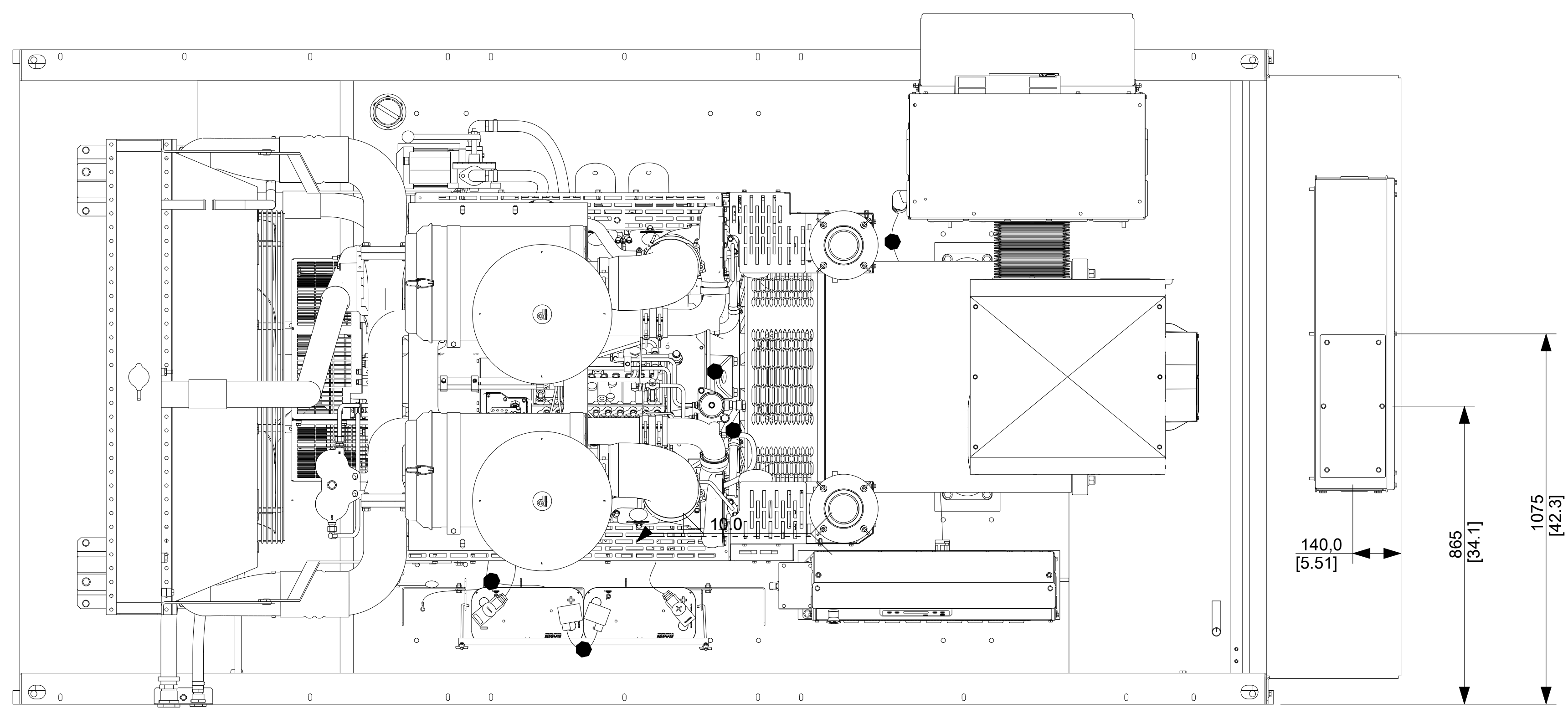
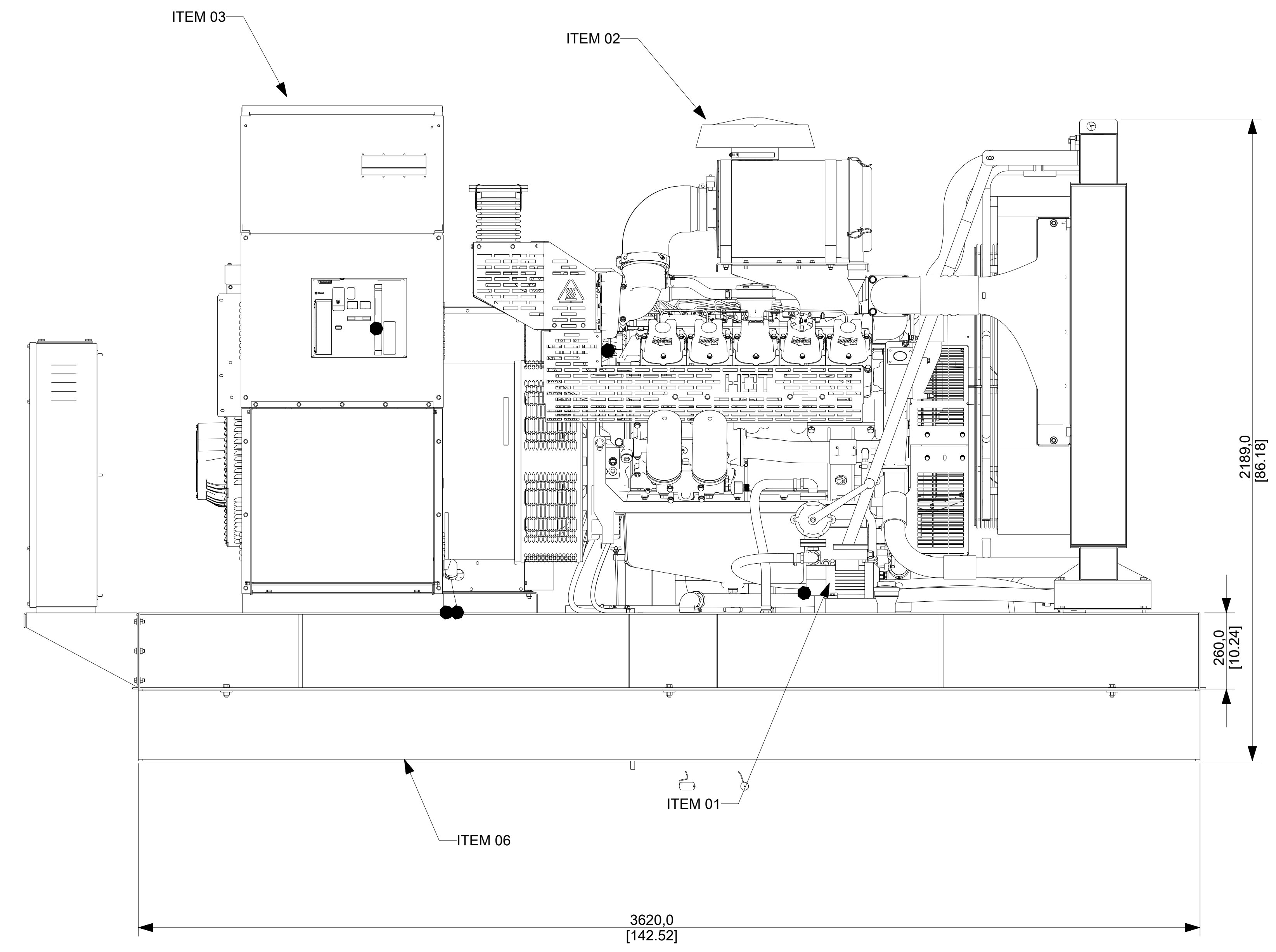
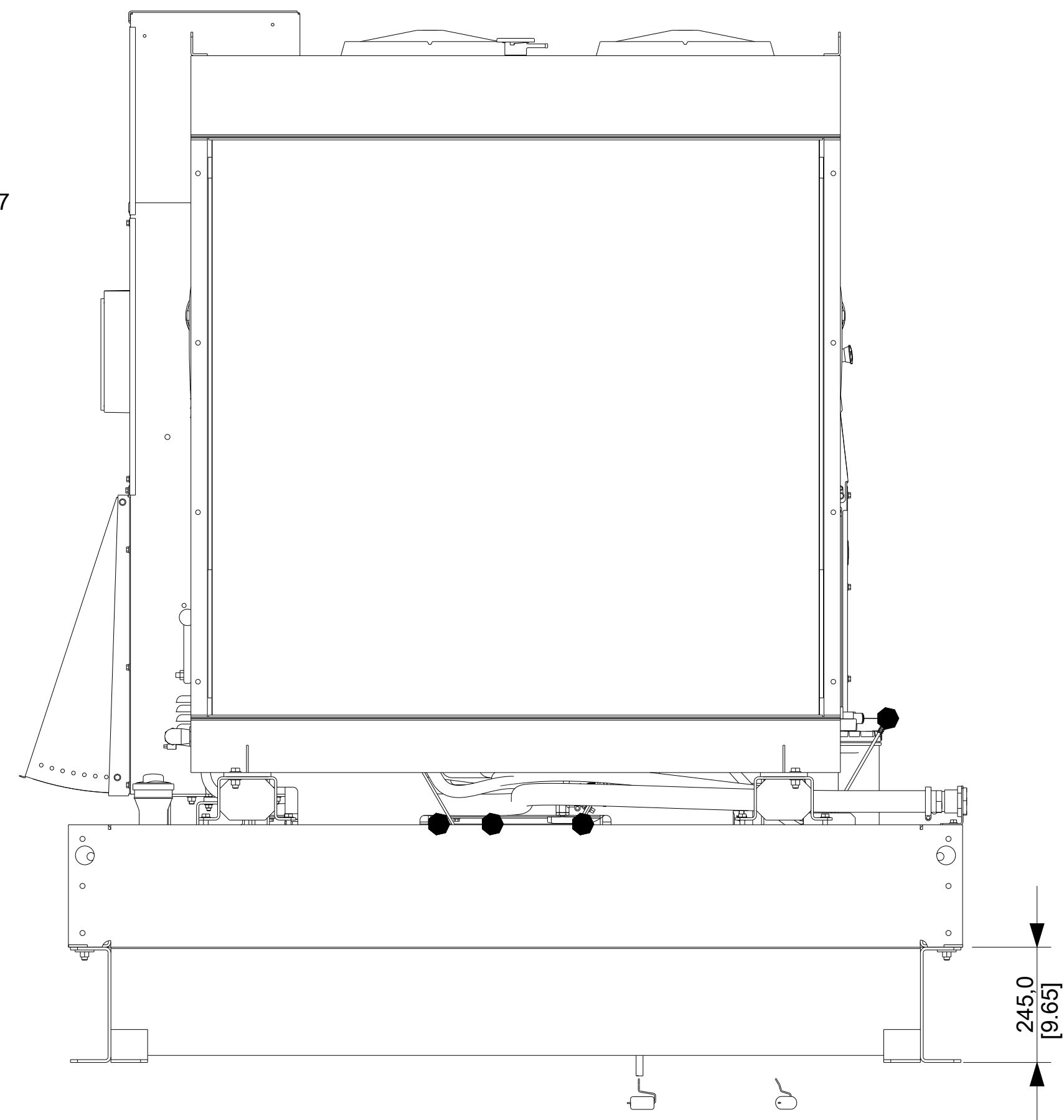
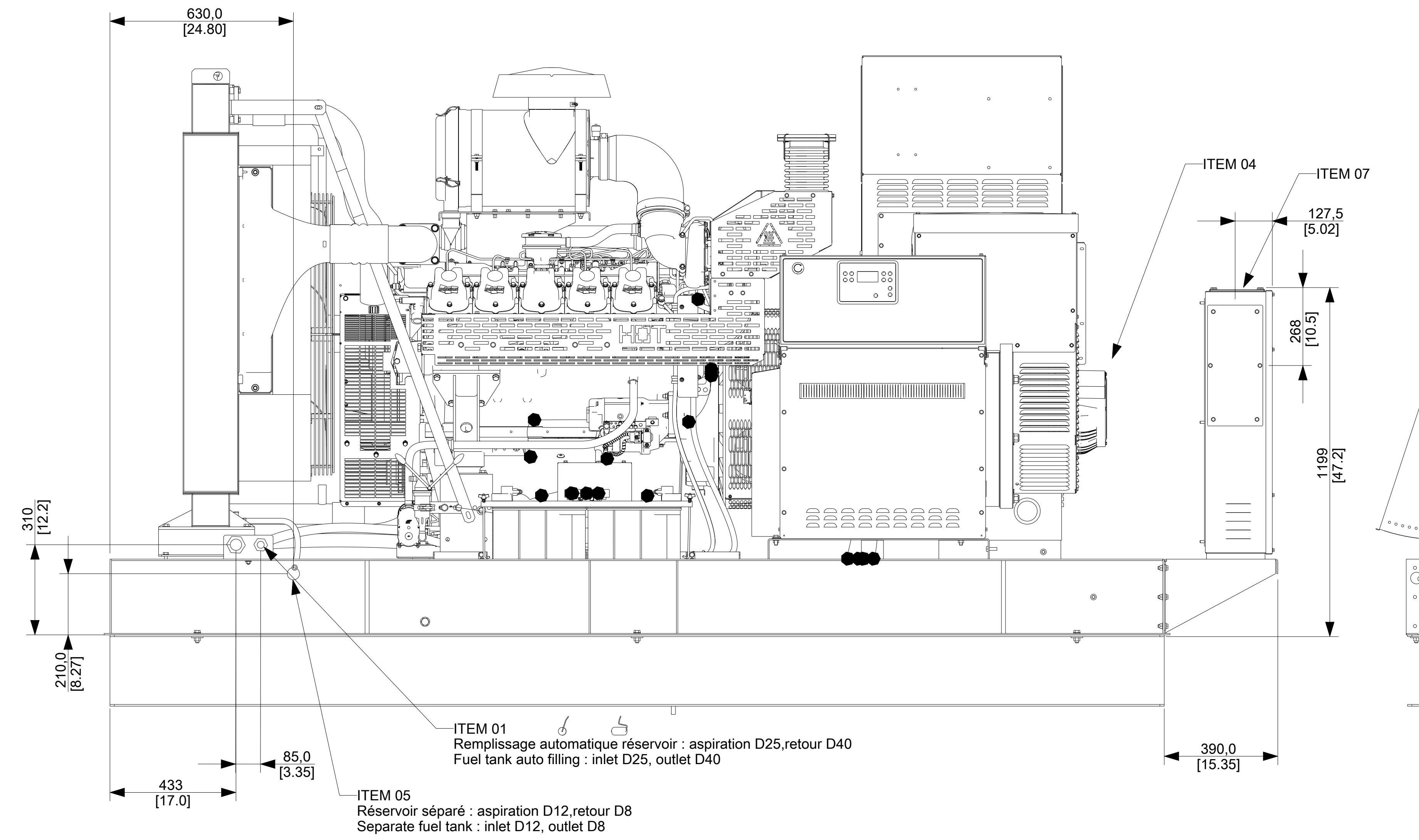

INFORMATIONS SUPPLEMENTAIRES / ADDITIONAL INFORMATION	ITEM
KIT REMPLISSAGE FUEL AUTOMATIQUE / AUTOMATIQUE FUEL FILL KIT	01
FILTRE A AIR AMBIANCE POUSSIEREUSE / HEAVY DUTY AIR FILTER	02
ARMOIRE AIPR SUPERIEUR / UPPER BRAKER BOX	03
PMG ALTERNATEUR / ALTERNATOR PMG	04
RACCORDEMENT FUEL SEPARÉ / FUEL CONNECTION	05
BAC DE RETENTION / RETENTION BUND	06
BORNIER UK / UK TERMINAL BLOCK	07

CET ASSEMBLAGE OU PIECE DOIT ETRE CONFORME A LA SPECIFICATION PEP-RML-001  
THIS ASSEMBLY OR PART MUST COMPLY WITH SPECIFICATION PEP-RML-001

REV	DATE	ON COMPOSITE DWGS. SEE PART NO. FOR REVISION LEVEL	BY	DO NOT SCALE. REFERENCE THE MODEL FOR ALL UNSPECIFIED DIMENSIONS
-	07/06/22	NEW DRAWING	SP	UNLESS OTHERWISE SPECIFIED - 1) DIMENSIONS ARE IN MILLIMETERS 2) TOLERANCES ARE: NF 501300-A4-E
A	14/03/24	UPDATE	SP	

**KOHLER.** 270 rue de Kerenem - 29490 Guipavas  
CS 40047 - 29801 Brest Cedex 9 - France

THIS DRAWING IS UNDER PROPERTY OF THE COMPANY.  
IT CANNOT PRINTED, USED OR COMMUNICATED WITHOUT ITS AUTHORIZATION.

TITLE: **30001546301**

CAD NO: 30001546301 SCALE: 1:10 SHEET: 2 of 3

DWG NO: **30001546301** REV: A SIZE: A0

APPROVALS: P. SIMON DATE: 14-Mar-24

Dimensions de transport / Delivery size

Version châssis avec ou sans réservoir -> Sans bac de rétention  
With or without tank frame version -> Without retention bund

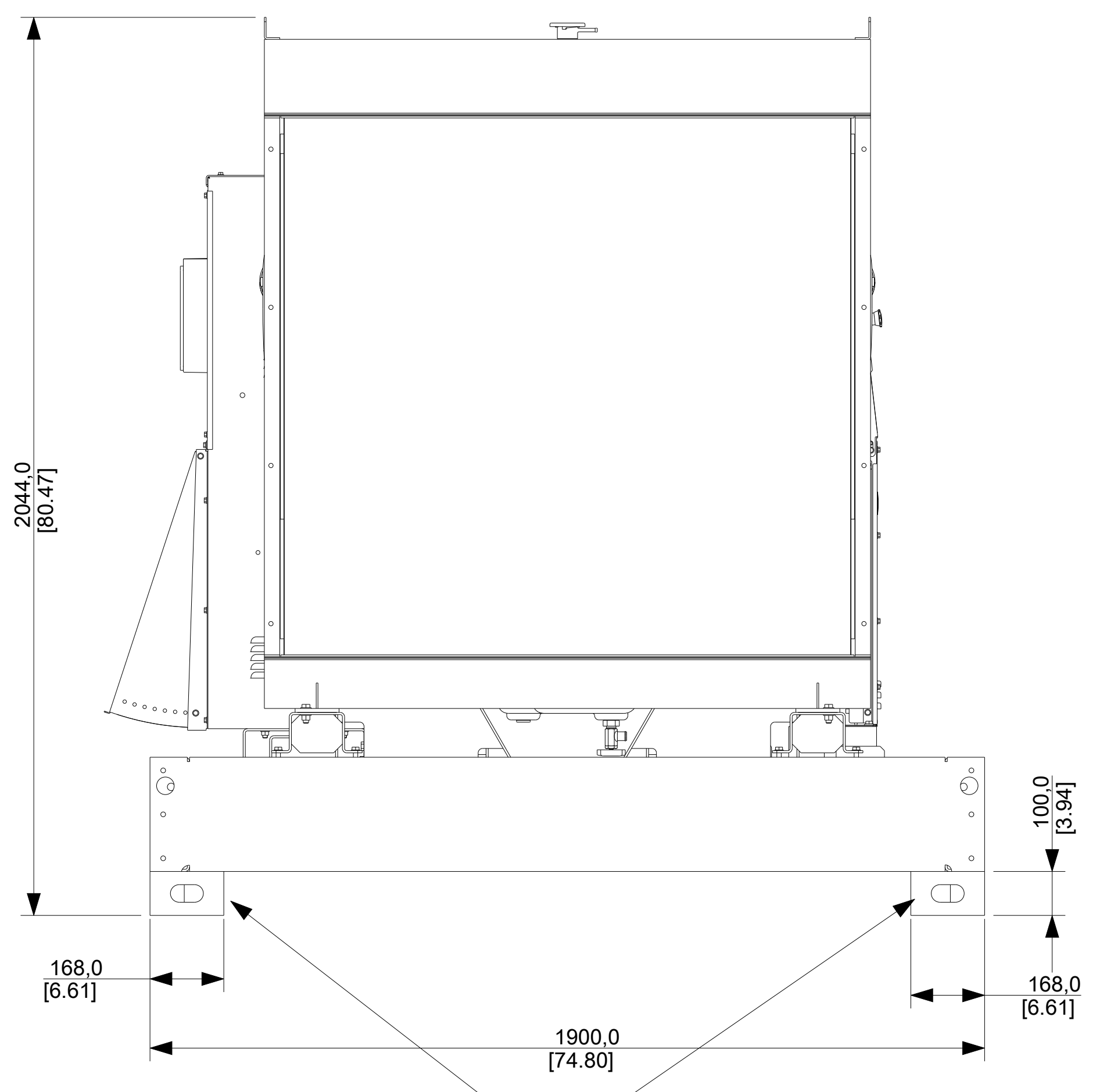
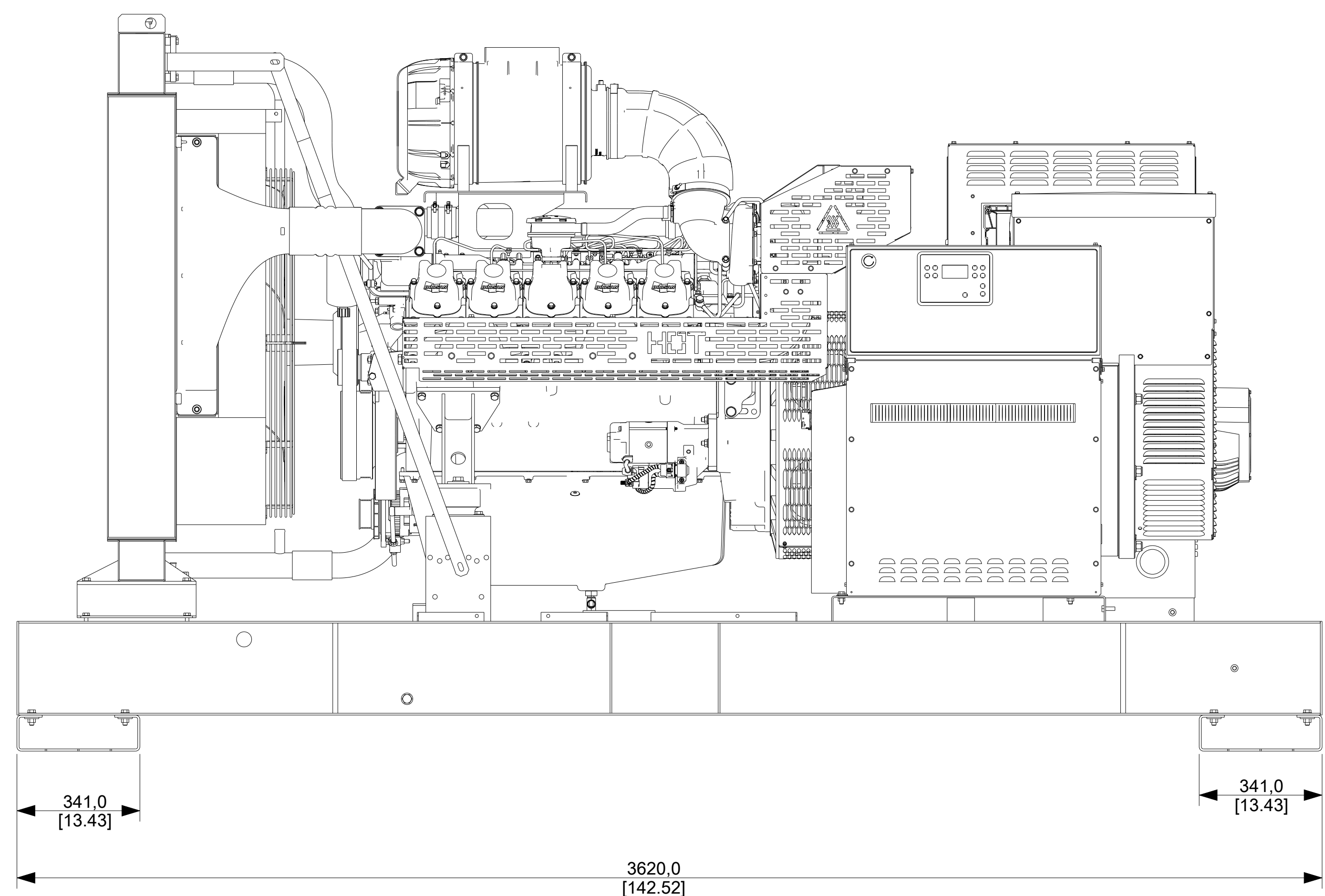

Eléments de manutention uniquement pour le transport à démonter pour l'installation du groupe électrogène  
Handling devices only for transportation must be unfitted to install the generator set

PLAN DE POSE AU SOL / GENSET FOOTPRINT

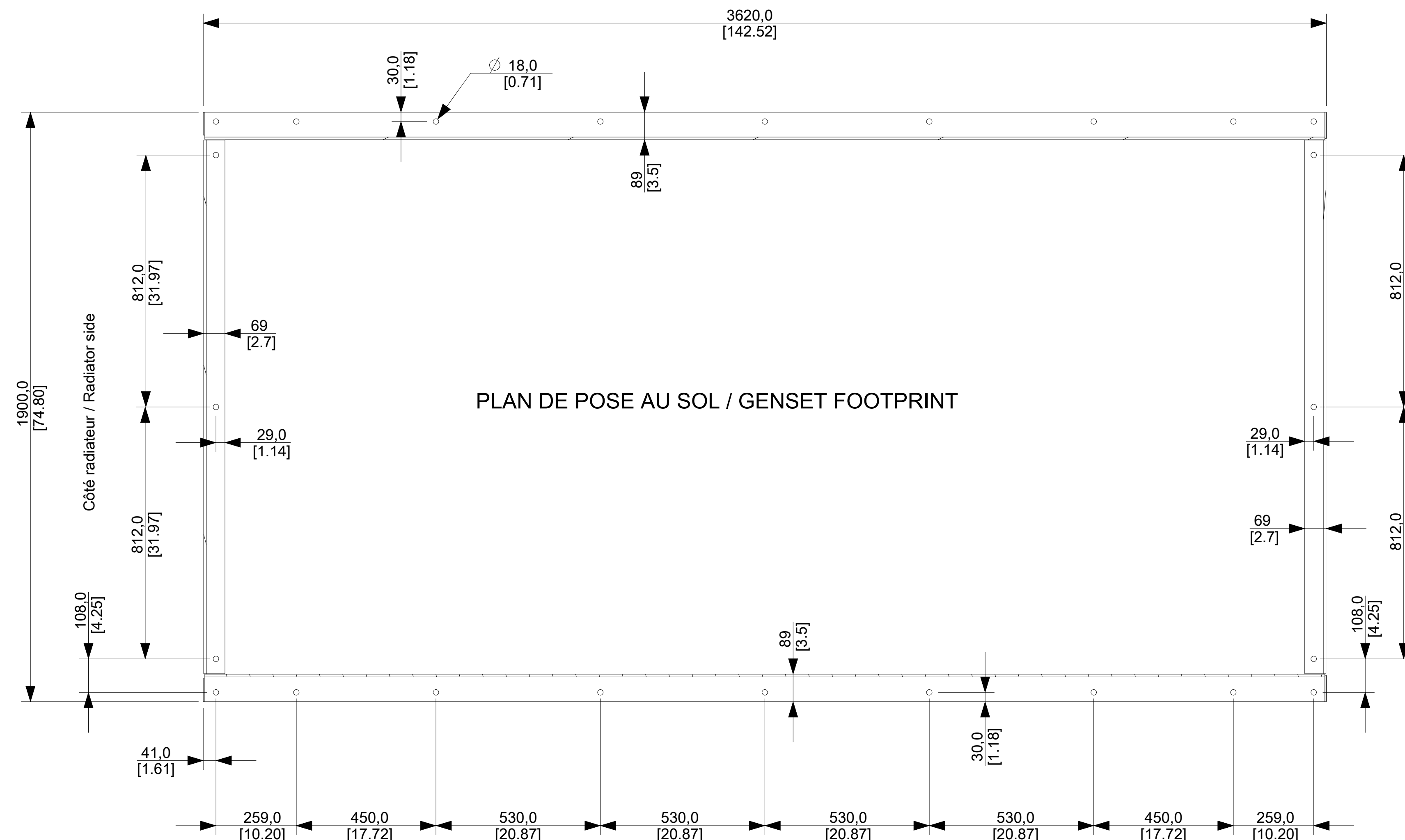

Dimensions de transport / Delivery size

Version châssis avec ou sans réservoir -> Avec bac de rétention  
With or without tank frame version -> With retention bund

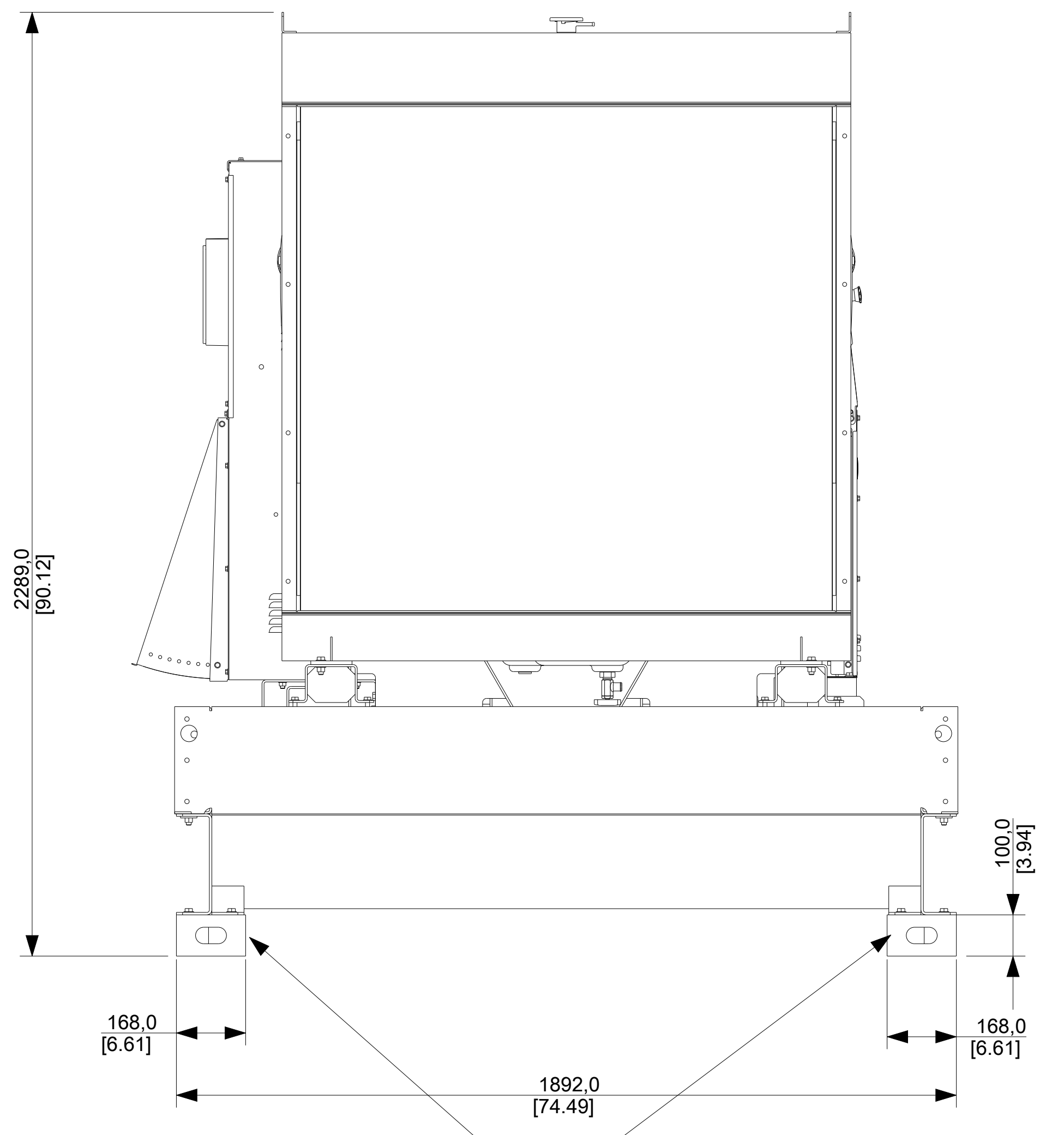
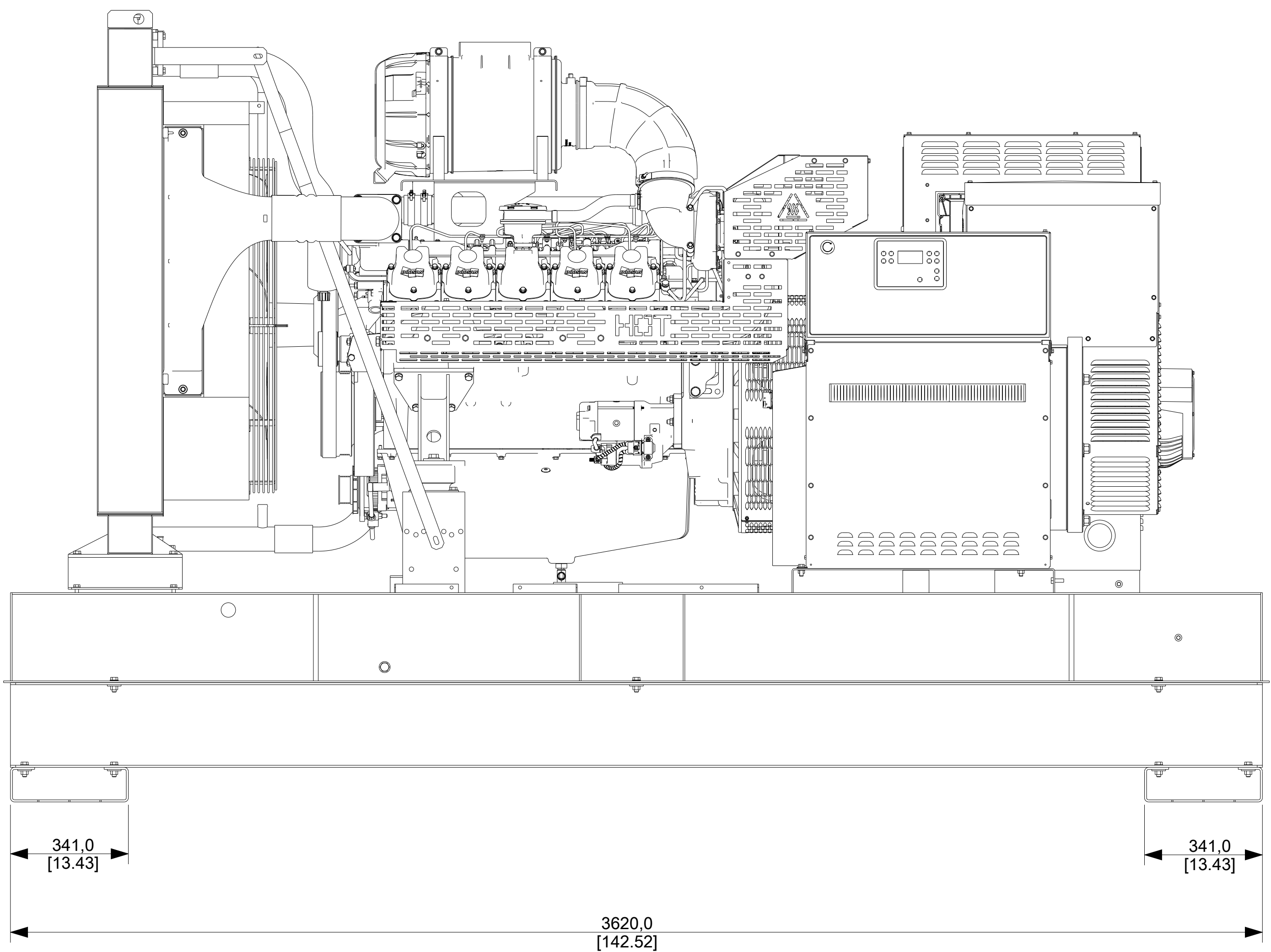

Eléments de manutention uniquement pour le transport à démonter pour l'installation du groupe électrogène  
Handling devices only for transportation must be unfitted to install the generator set

PLAN DE POSE AU SOL / GENSET FOOTPRINT



CET ASSEMBLAGE OU PIECE DOIT ETRE CONFORME A LA SPECIFICATION PEP-RML-001  
THIS ASSEMBLY OR PART MUST COMPLY WITH SPECIFICATION PEP-RML-001

REV	DATE	ON COMPOSITE DWGS. SEE PART NO. FOR REVISION LEVEL	BY	DO NOT SCALE. REFERENCE THE MODEL FOR ALL UNSPECIFIED DIMENSIONS
-	07/06/22	NEW DRAWING	SP	UNLESS OTHERWISE SPECIFIED - 1) DIMENSIONS ARE IN MILLIMETERS 2) TOLERANCES ARE: NF ISO 1300-A-E
A	14/03/24	UPDATE	SP	

APPROVALS	DATE	TITLE	SCALE	SHEET
P. SIMON	14-Mar-24	30001546301	1:10	3 of 3
		30001546301		REV. SIZE
				A A0



THIS DRAWING IS UNDER PROPERTY OF THE COMPANY. IT CANNOT PRINTED, USED OR COMMUNICATED WITHOUT ITS AUTHORIZATION.