

GAUCHE / LEFT

AVANT / FRONT

DROITE / RIGHT

ARRIERE / BACK

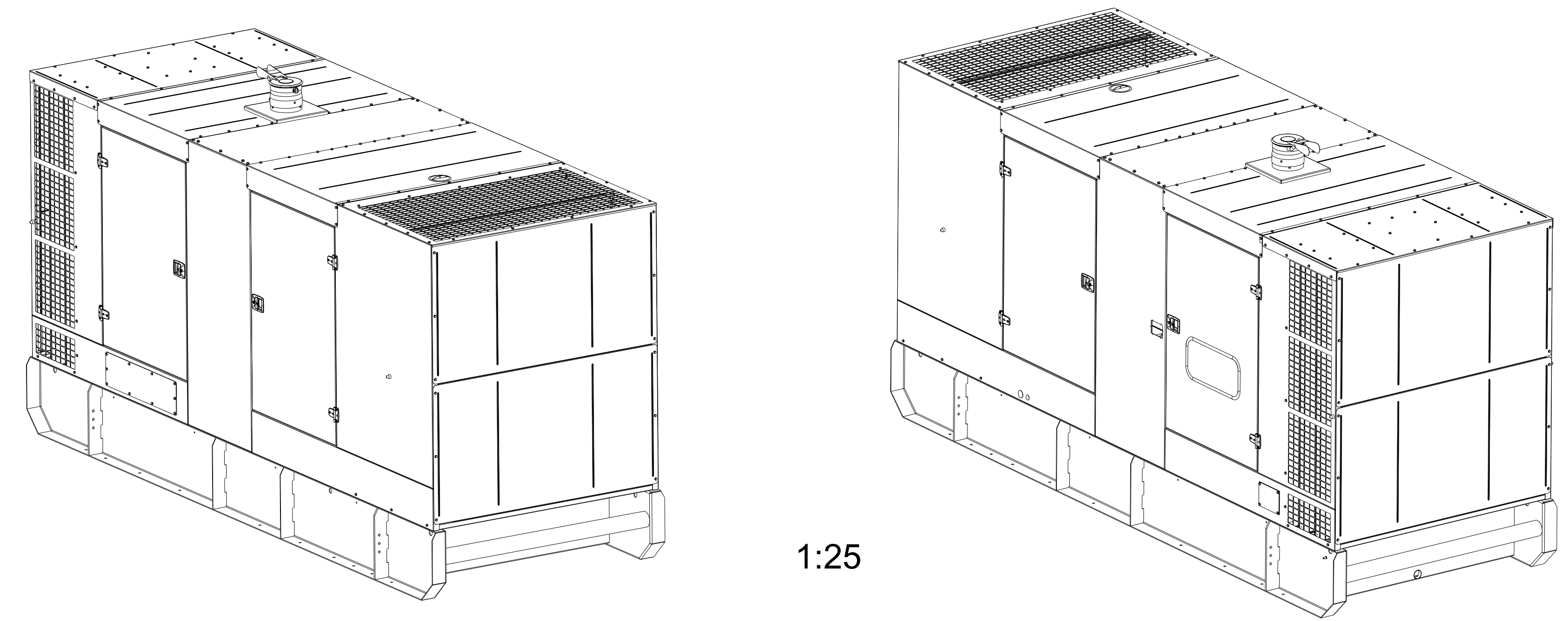
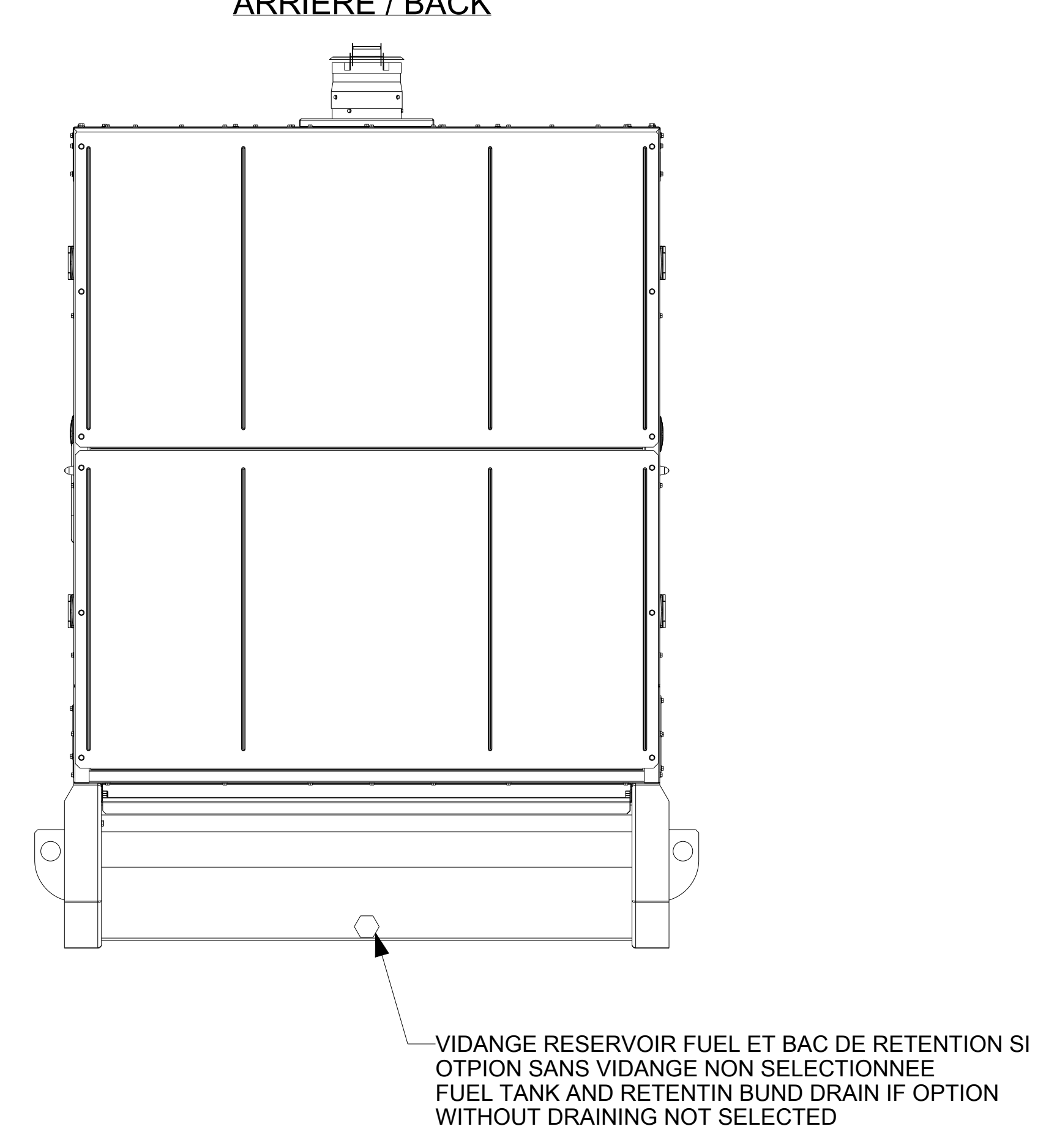
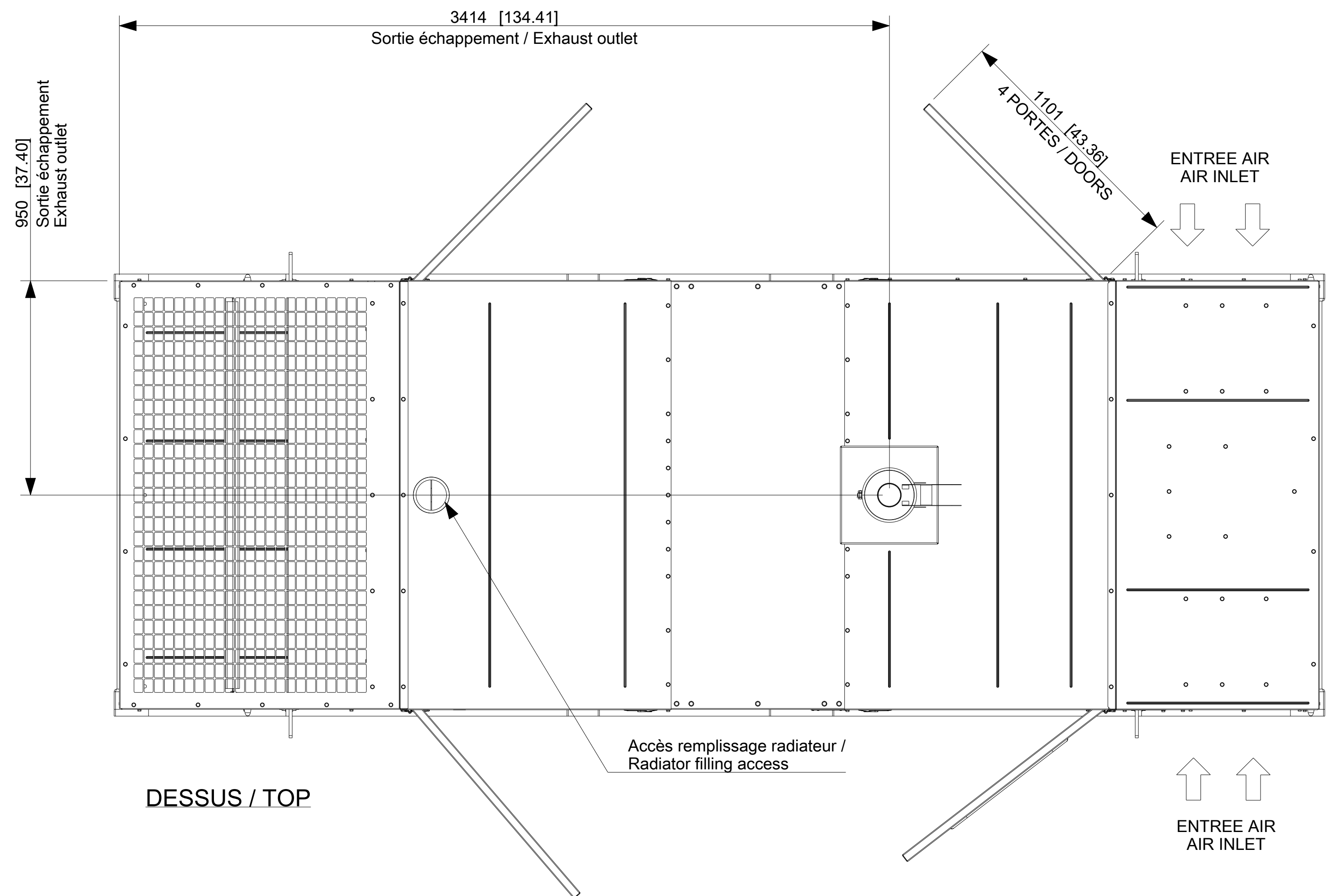
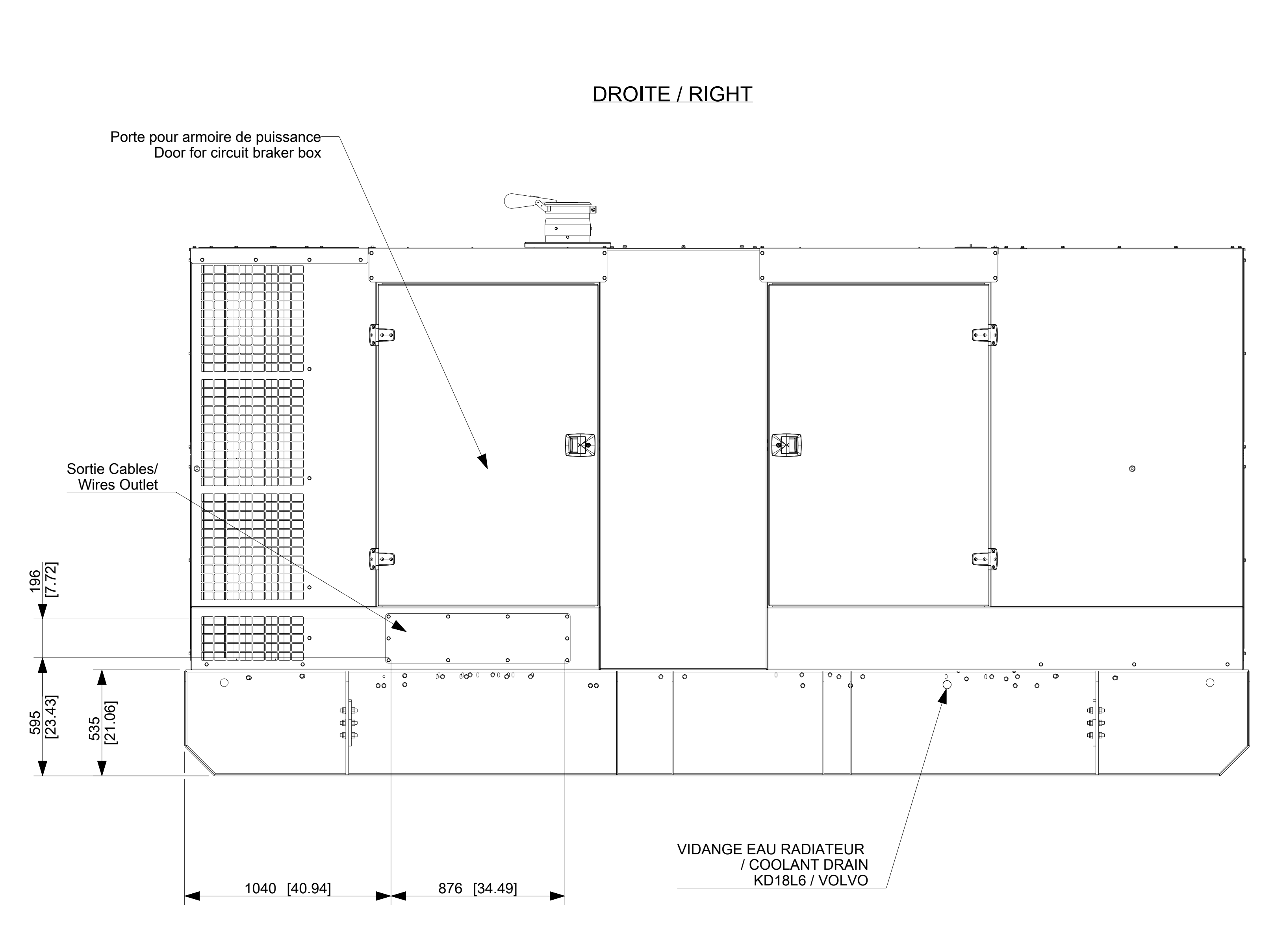
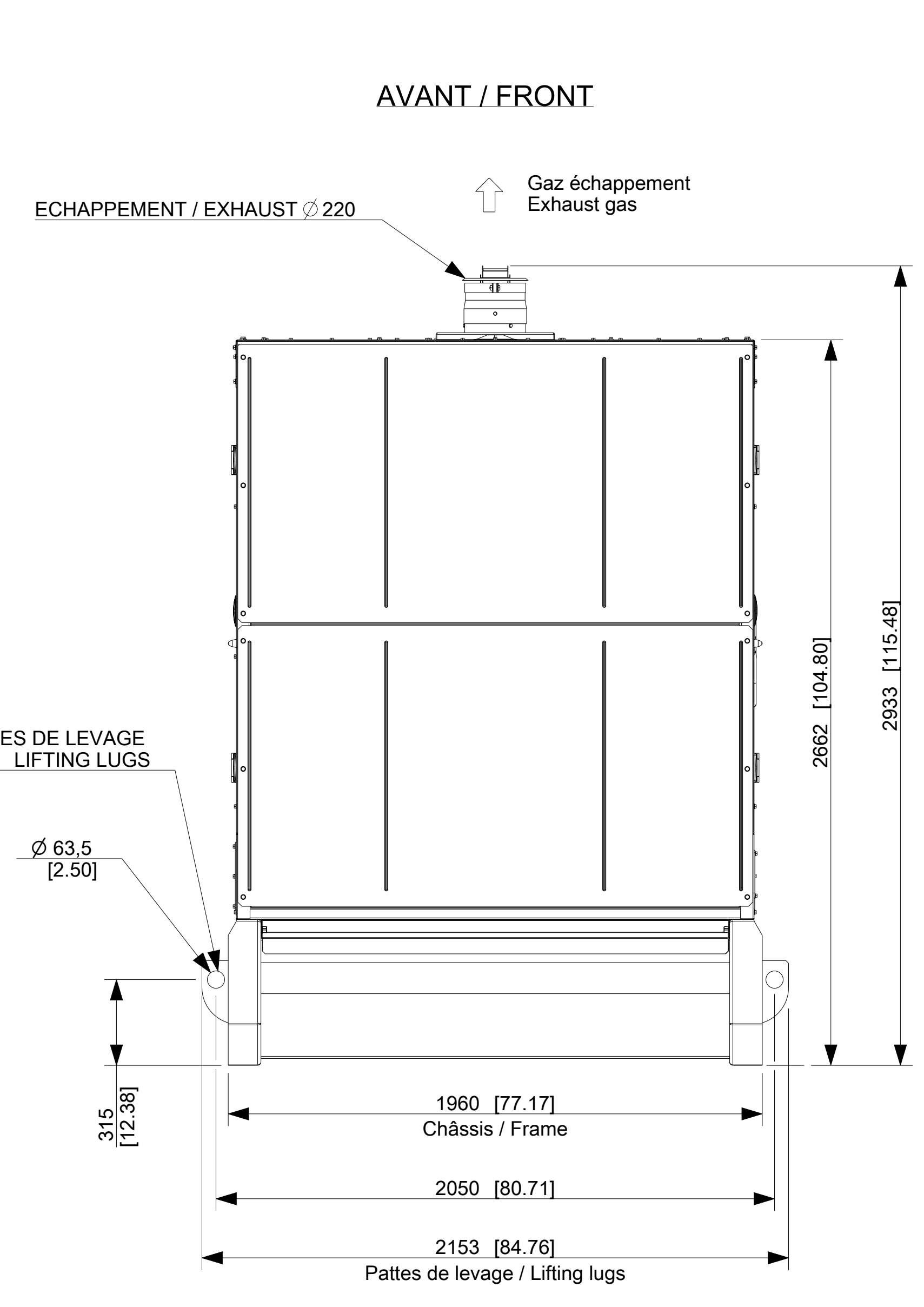
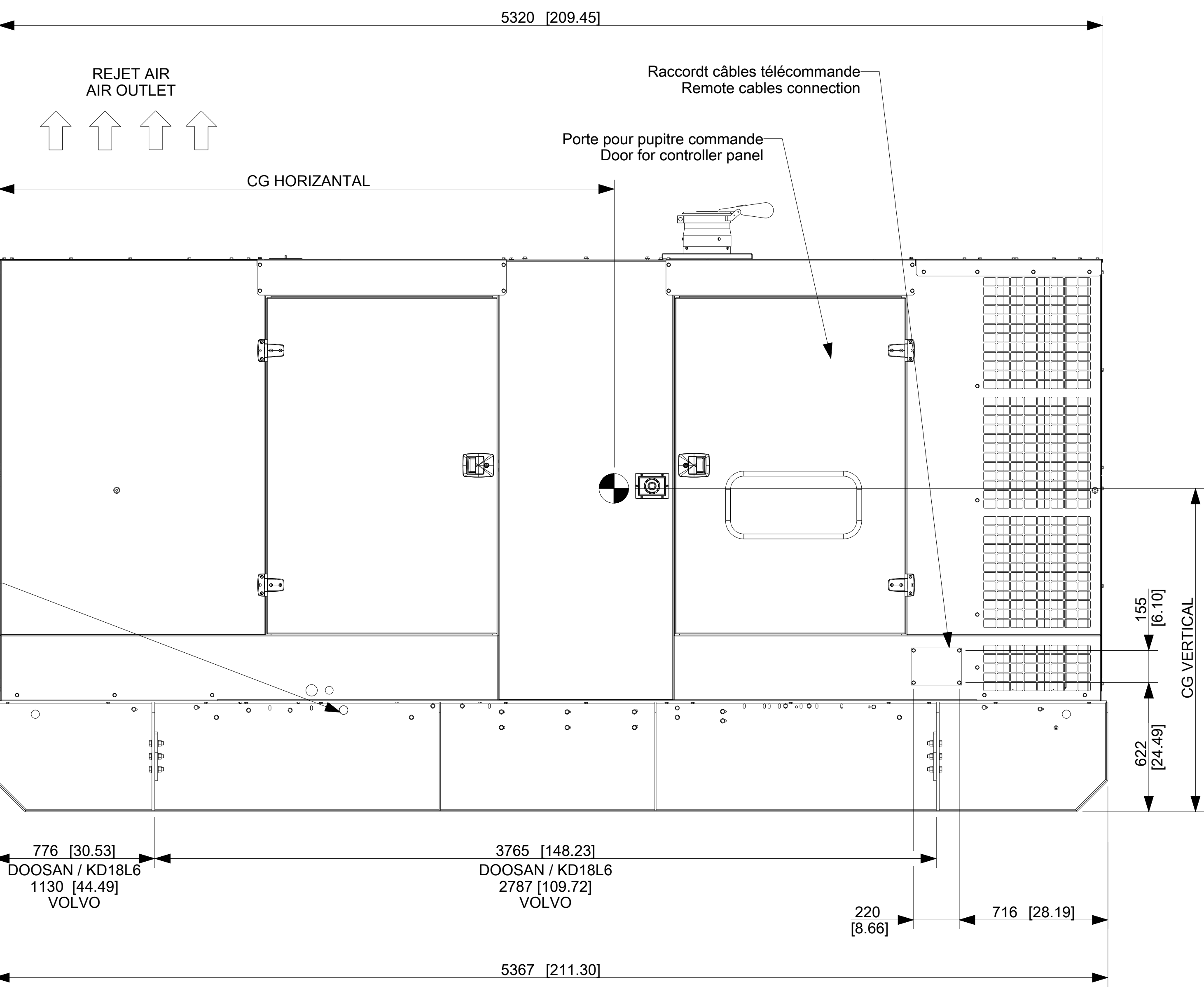

MOTEUR ENGINE	ALTERNATEUR ALTERNATOR	CHASSIS DB-WALL / DB-WALL FRAME			
		MASSE / WEIGHT (kg / lbs) +/- 5%		COG (mm / inch)	
		A vide / Dry	OdM / Wet	CG Horizontal	CG Vertical
DOOSAN DP180LA	KH02713T	6581 / 14508	8676 / 19127	3154 / 124	1095 / 43
	KH02954T	6663 / 14689	8758 / 19308	3163 / 124	1094 / 43
	KH03546T	6950 / 15322	9044 / 19938	3184 / 124	1093 / 43
DOOSAN DP180LB	KH02954T	6671 / 14707	8766 / 19325	3161 / 124	1096 / 43
	KH02713T	6589 / 14526	8684 / 19144	3152 / 124	1097 / 43
	KH03546T	6898 / 15207	8993 / 19826	3197 / 125	1094 / 43
DOOSAN DP222LC	KH03546T	7238 / 15957	9366 / 20648	3136 / 123	1080 / 43
	KH03546T	7850 / 17296	10090 / 22253	2800 / 110	847 / 33
KOHLER KD18L6	KH02970T	8020 / 17680	10270 / 22637	2800 / 110	857 / 34
	KH01983T	6560 / 14456	8770 / 19344	2920 / 115	930 / 37
VOLVO TAD1641GE	KH02215T	6670 / 14716	8890 / 19604	2940 / 116	930 / 37
	KH02713T	6810 / 15021	9030 / 19909	2960 / 117	930 / 37
VOLVO TAD1642GE	KH02215T	6670 / 14716	8890 / 19604	2940 / 116	930 / 37
	KH02713T	6810 / 15021	9030 / 19909	2960 / 117	930 / 37
VOLVO TAD1644GE	KH02954T	6890 / 15197	9110 / 20085	2960 / 117	930 / 37
	KH02954T	7280 / 16048	9600 / 21159	2930 / 115	950 / 38
VOLVO TWD1644GE	KH02954T	7280 / 16048	9600 / 21159	2930 / 115	950 / 38
	KH03546T	7500 / 16536	9820 / 21647	2960 / 117	950 / 38

- Voir folios suivants pour informations complémentaires  
See following sheets for additional informations.

- Les noms des vues correspondent aux différentes faces du groupe électrogène  
The names of the views correspond to the different sides of the generating set.

- Dimensions [ Inch ]

REV	DATE	DESCRIPTION	BY	APPR
1	21FEB2023	NEW DRAWING	APM	
2	21FEB2023	DRAWING UPDATED	SSH	
3	21FEB2023	TWO-DIMENSIONS ADDED IN WEIGHT TABLE	LLG	
4	14/03/24	UPDATE	SP	

SCALE: 1:15 (SHEET SIZE: A0) SHEET 1 OF 2

**KOHLER**

PLAN-GE-CP  
-EX4-M240-FRAME-DBW  
30001548601

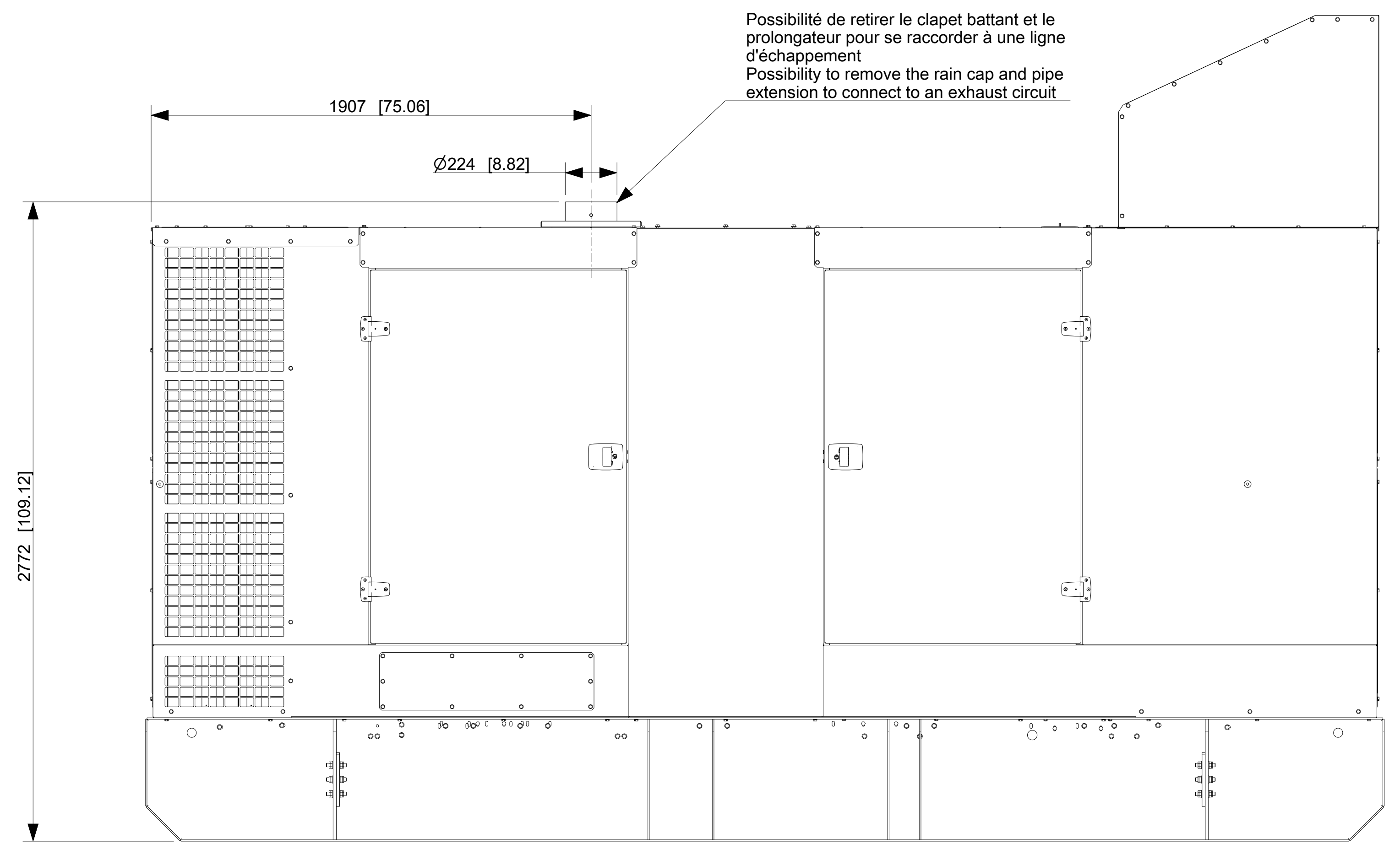
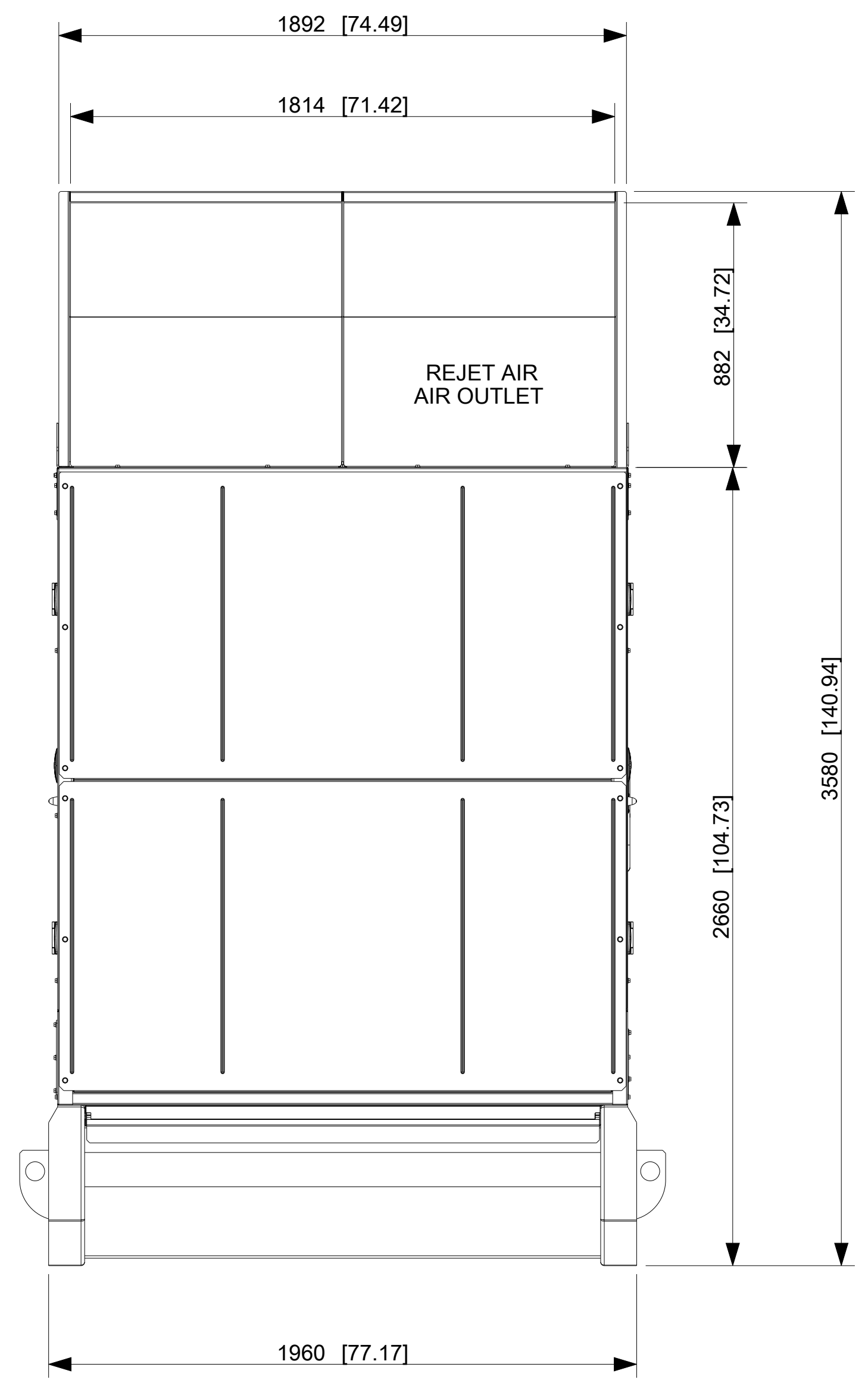
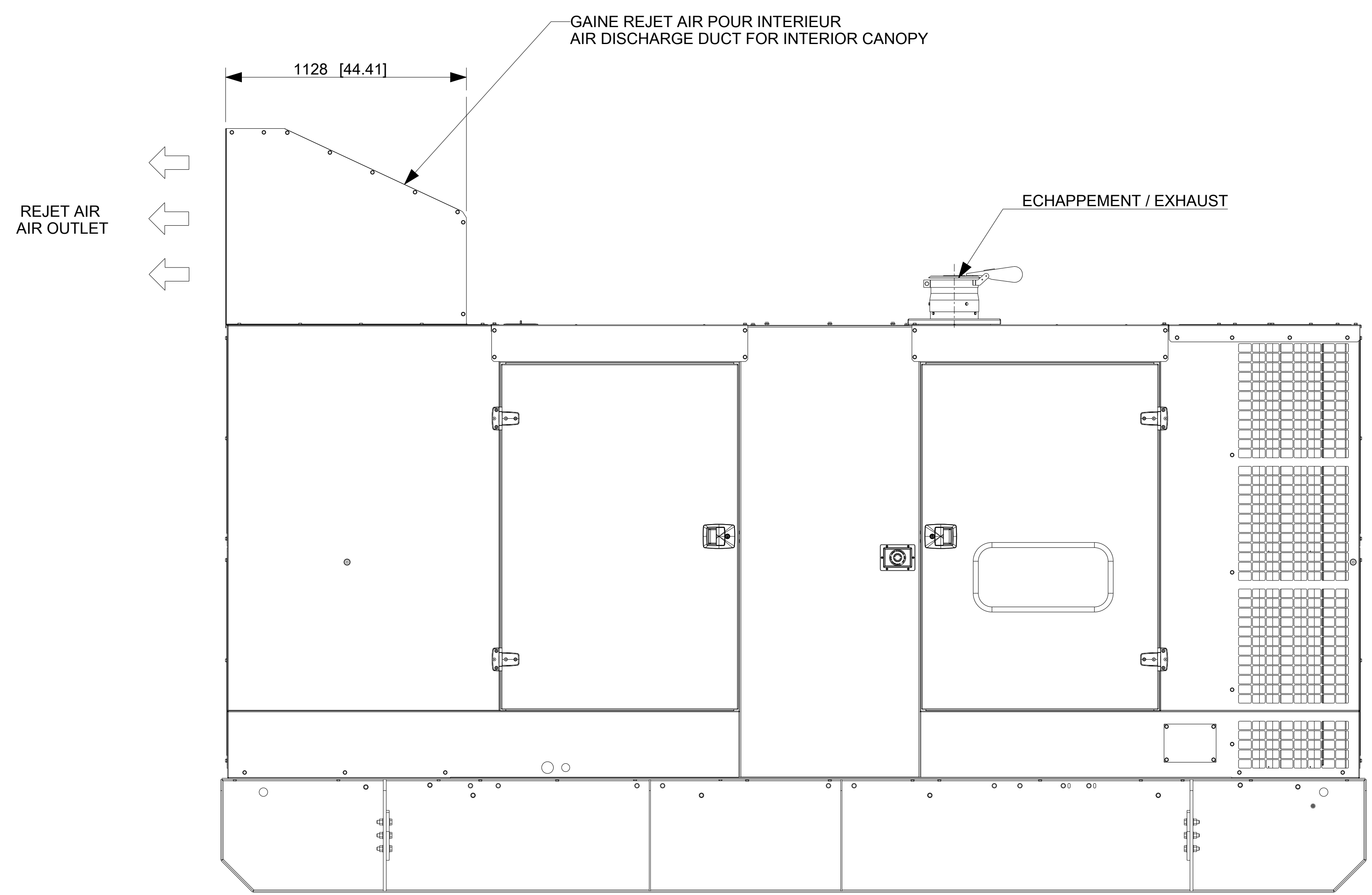

**DIMENSIONS DE TRANSPORT  
OVERALL DIMENSIONS FOR TRANSPORT**

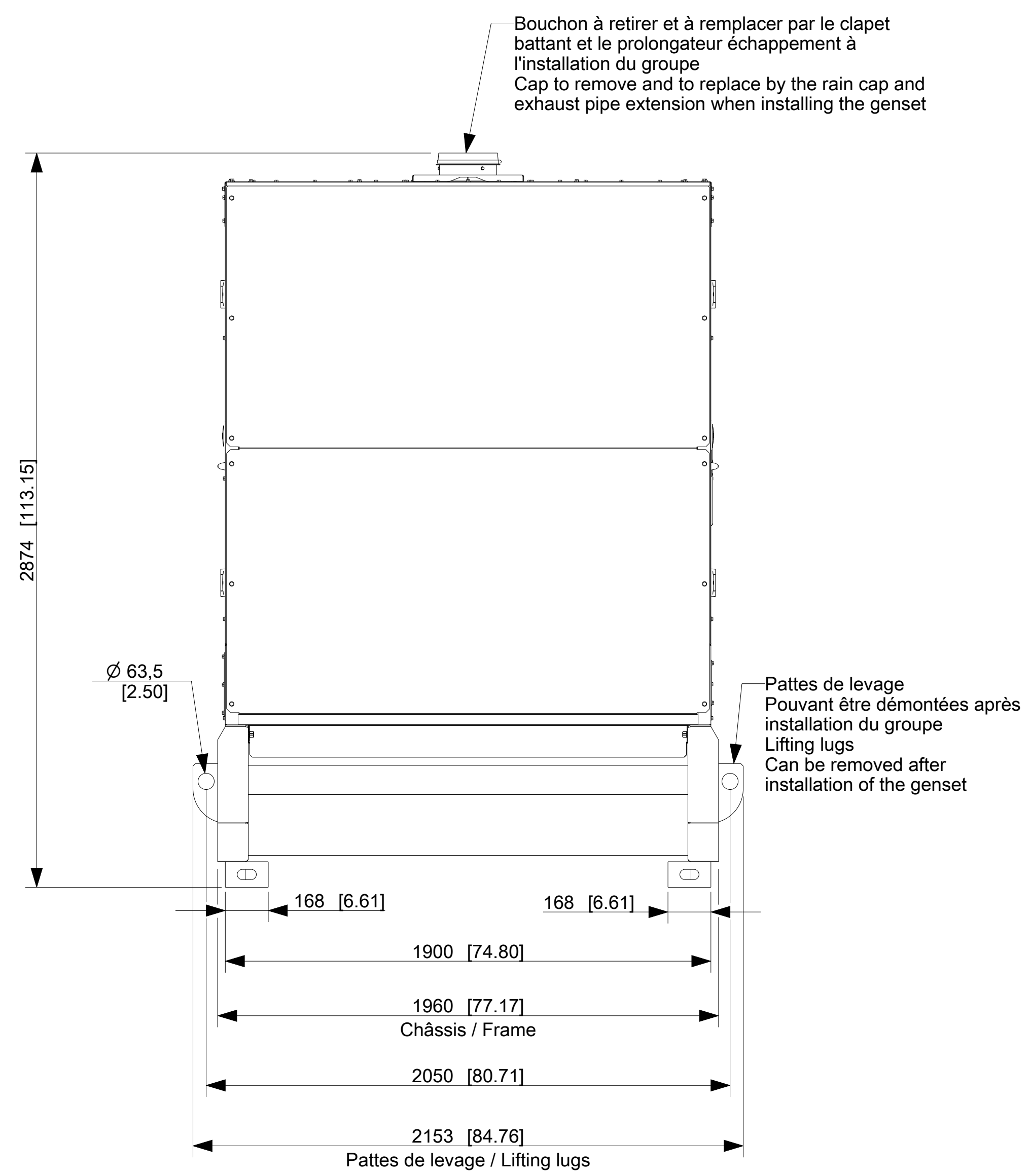
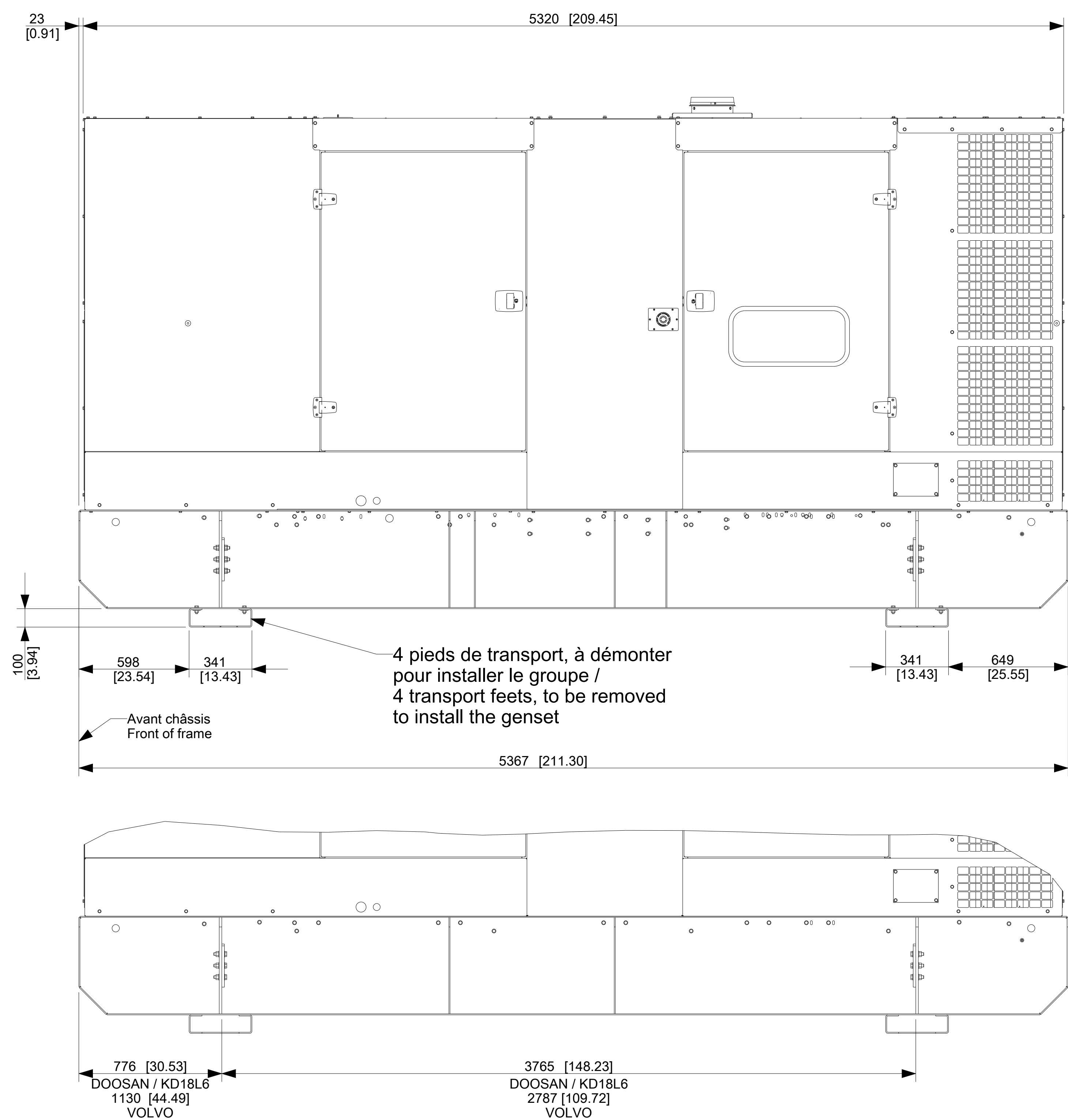

**PLAN DE POSE AU SOL / GENSET FOOTPRINT**

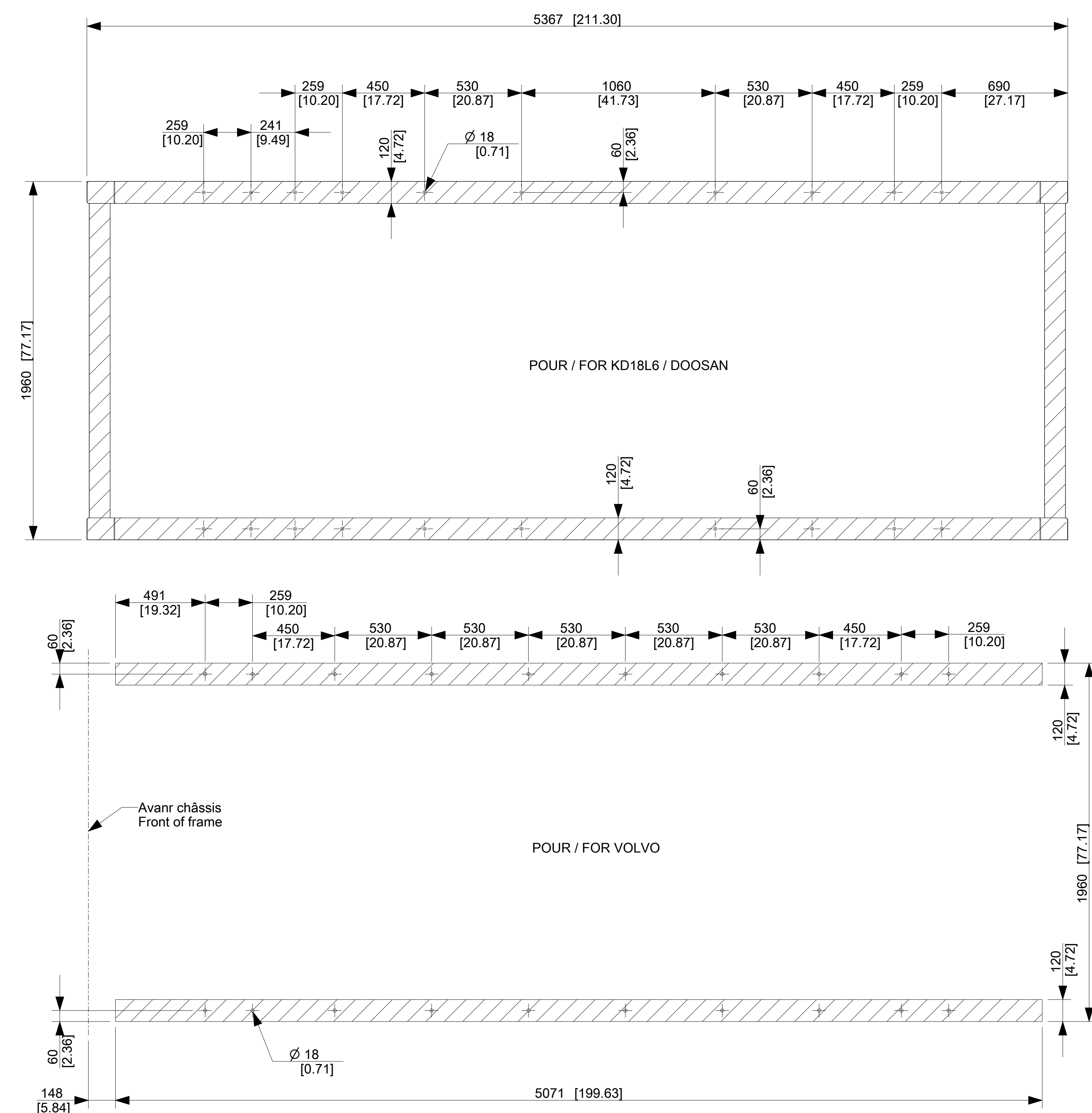

REV	DATE	DESCRIPTION	BY	APPR
1	21FEB2023	NEW DRAWING	APM	
2	21FEB2023	DRAWING UPDATED	SSH	
3	14/03/24	UPDATE	SP	

UNLESS OTHERWISE SPECIFIED, ALL DIMENSIONS ARE IN MILLIMETERS (IN PARENTHESES).	UNLESS OTHERWISE SPECIFIED, ALL DIMENSIONS ARE IN MILLIMETERS (IN PARENTHESES).
THIS ASSEMBLY OR PART MUST COMPLY WITH ORIGINAL COU. REFERENCE CAD MODEL FOR UNSPECIFIED DIMENSIONS.	THIS ASSEMBLY OR PART MUST COMPLY WITH ORIGINAL COU. REFERENCE CAD MODEL FOR UNSPECIFIED DIMENSIONS.

**KOHLER**

SCALE: 1:15 (SHEET SIZE: A0) SHEET: 2 OF 2

**PLAN-GE-CP**  
**-EX4-M240-FRAME-DBW**  
DESIGN NO. 30001548601