

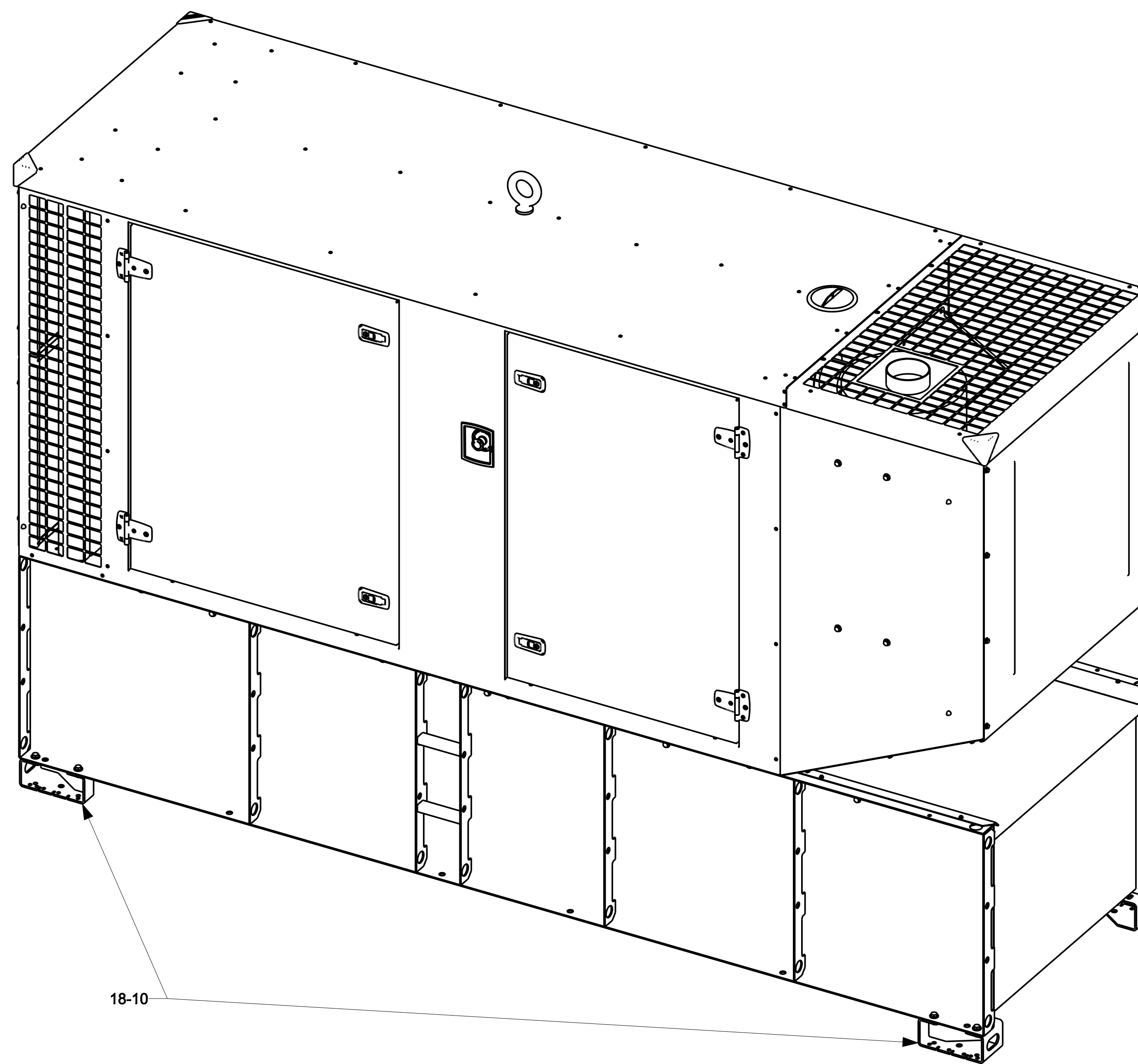

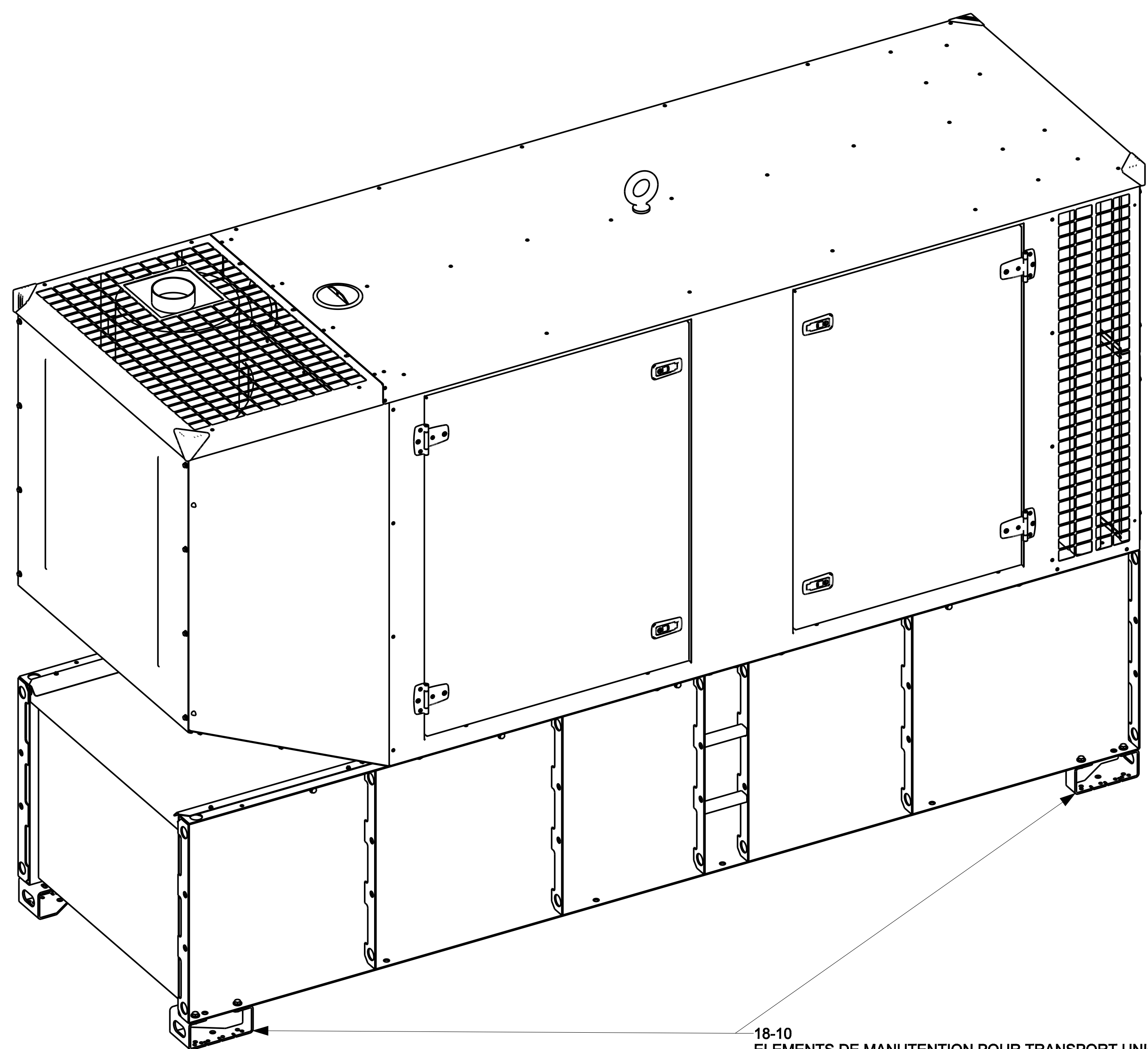

DIMENSIONS DE TRANSPORT  
 OVERALL DIMENSIONS FOR TRANSPORT  
 ATTENTION !! LA MANUTENTION DU GROUPE DOIT ETRE FAITE SANS LE PLEIN DE FUEL  
 WARNING !! HANDLING OF GENSET MUST BE MADE WITHOUT FUEL

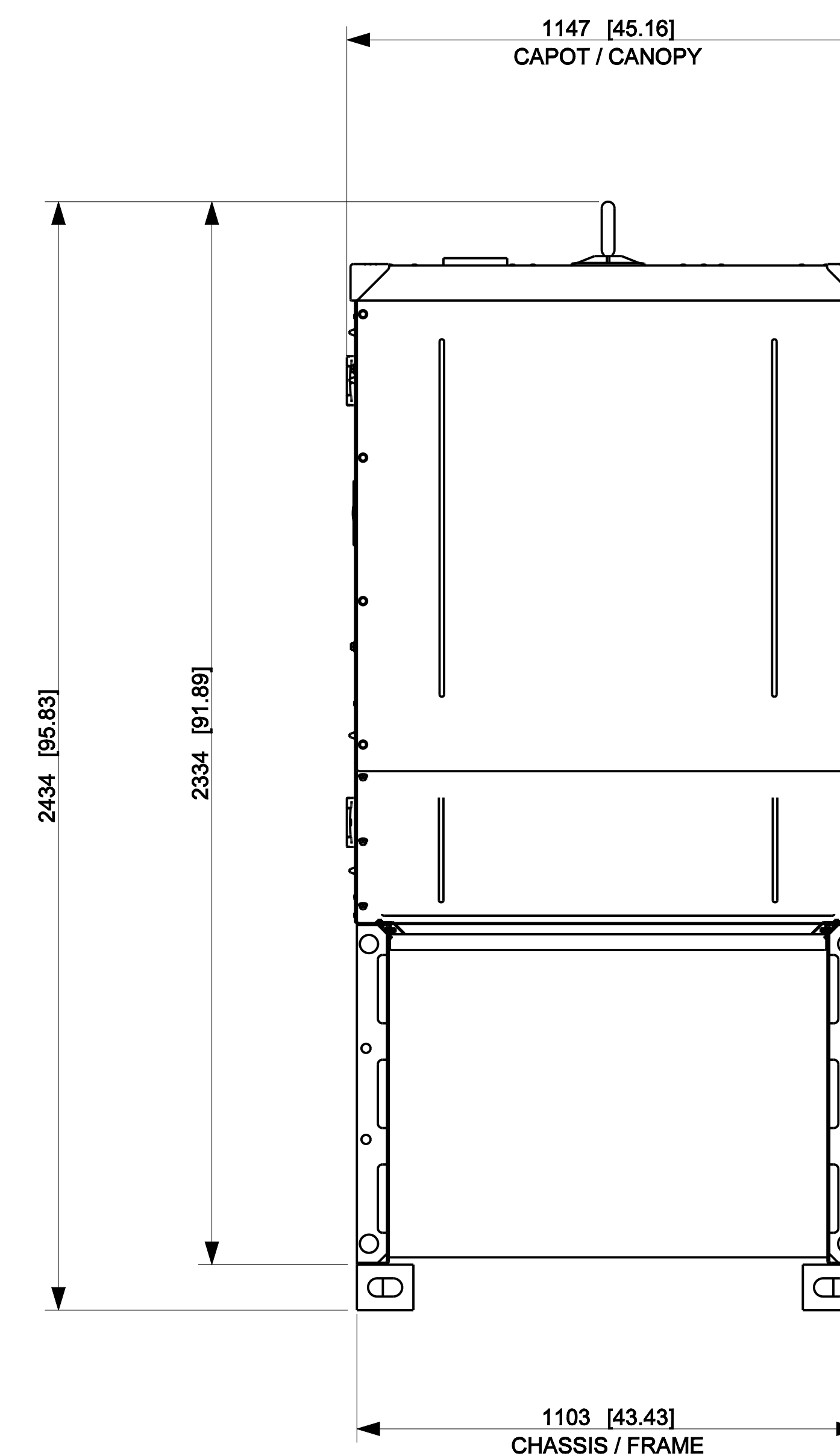
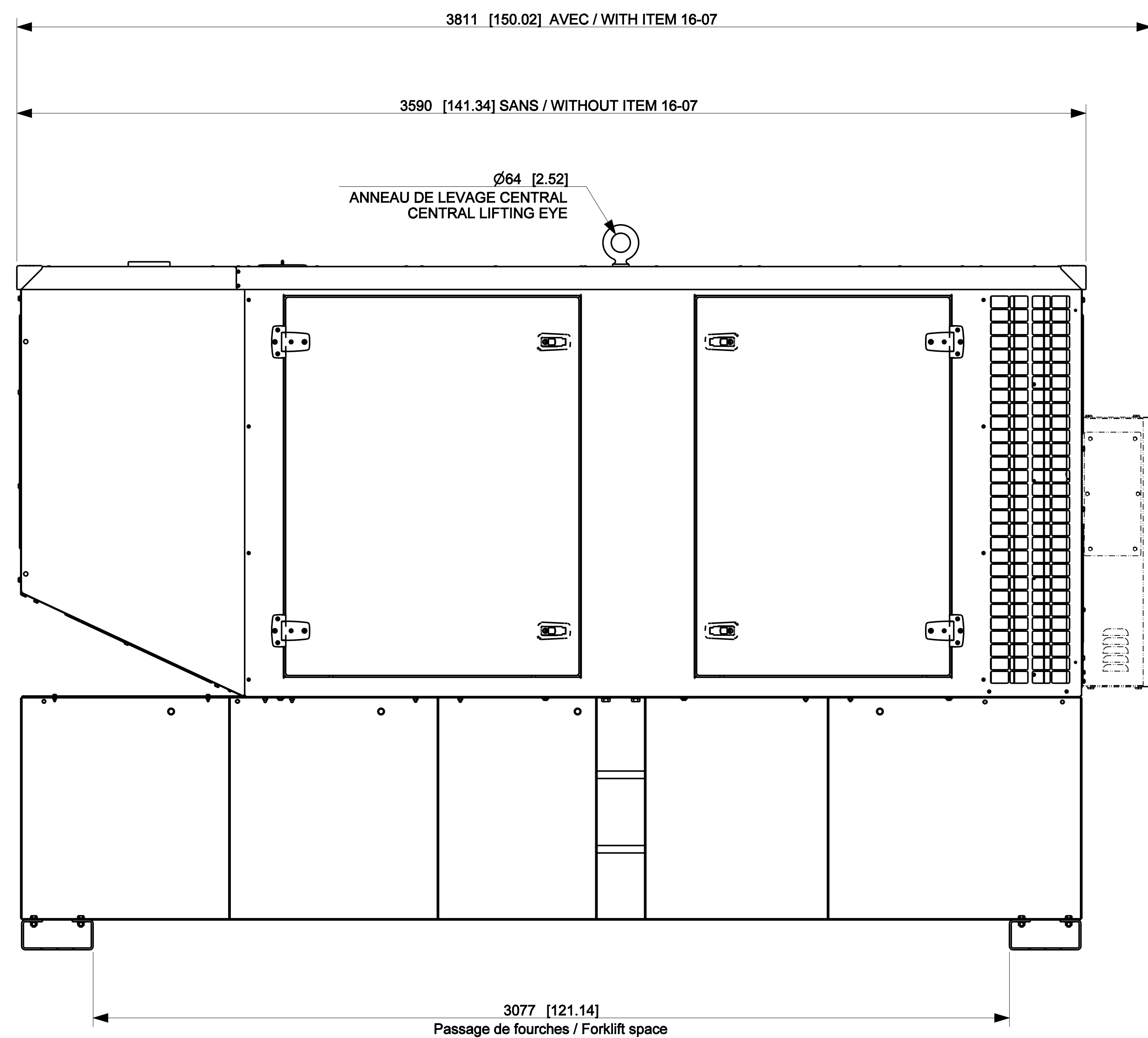

18-10  
 ELEMENTS DE MANUTENTION POUR TRANSPORT UNIQUEMENT. A DEMONTER A L'INSTALLATION DU GROUPE ELECTROGENE  
 HANDLING DEVICES ONLY FOR TRANSPORTATION. MUST BE UNFITTING IN ORDER TO INSTALL THE GENERATING SET.

Ce plan vous est remis à titre indicatif et peut être révisé sans préavis.  
 This drawing is for informational purposes only and maybe changed whitout notice.

REV	DATE	CHANGEMENTS	BY	THIS ASSEMBLY OR PART MUST COMPLY WITH THE LATEST REVISIONS OF THE DRAWING	DO NOT SCALE.	
01	08AUG2025	RELEASE FOR PRODUCTION	STN			
UNLESS OTHERWISE SPECIFIED 1) DIMENSIONS ARE IN MILLIMETERS 2) DIMENSIONS ARE TO CENTERLINE UNLESS NOTED OTHERWISE			GROUP: 10 CRITICAL: # 2 MANUFACTURING QUANTITY: 1000		MODEL: 110 - SHEET REF: AD - SHEET 3 OF 3 TITLE: DIMENSION PRINT, M149 CANOPY, DW46H DWG NO.: 30001471501	
APPROVED: [Signature] DESIGNED: [Signature]			DRAWN: STN DATE: 08AUG2025		THIS DRAWING IS BOMI INTELLECTUAL PROPERTY AND MUST NOT BE USED OUTSIDE OF BOMI INDUSTRIES WORK. ALL RIGHTS OF DESIGN OR INVENTION ARE RESERVED.	